



MOVING YOU FURTHER

**25-30**

**33L-9A**

**35LN-9A**



Some of the photos may include optional equipment.





# Your satisfaction is our priority!

## New LPG Forklift with Proven Quality and Advanced Technology

Hyundai introduces a new line of 9-series LPG forklift trucks.

The newly designed 4 wheel counterbalance trucks provide every operator comfortable driving, increased productivity and easy maintenance.

#### High Efficiency

- Tier 4, High power engine : HMC L4KB (60PS/44.1kW)
- Reduce inching impact : Clutch protection system
- Wet disc brake

#### Advanced Safety

- Auto parking brake system
- Hill Start Assist Control
- Operator Presence Sensing System (OPSS)
- Machine inclination indication

#### Best Convenience

- 5.6 inch LCD color monitor
- Auto fork leveling system (OPT)
- Load weight indicator

#### Easy Maintenance

- Password starting system
- Consumable item replacement cycle warning
- Rear tire cover & under cover (OPT)





Power & Performance

# High Efficiency & Optimal Performance

Powerful engine and high technology systems provide you with enhanced performance and highest productivity.

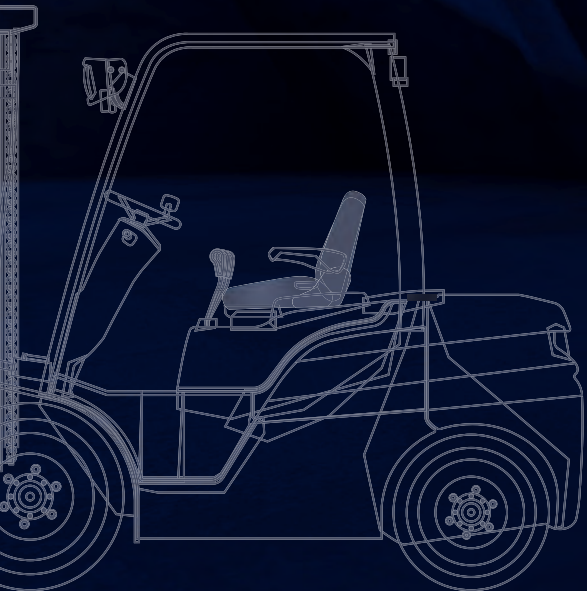

HIGH PERFORMANCE

POWERFUL ENGINE

Some of the photos may include optional equipment.

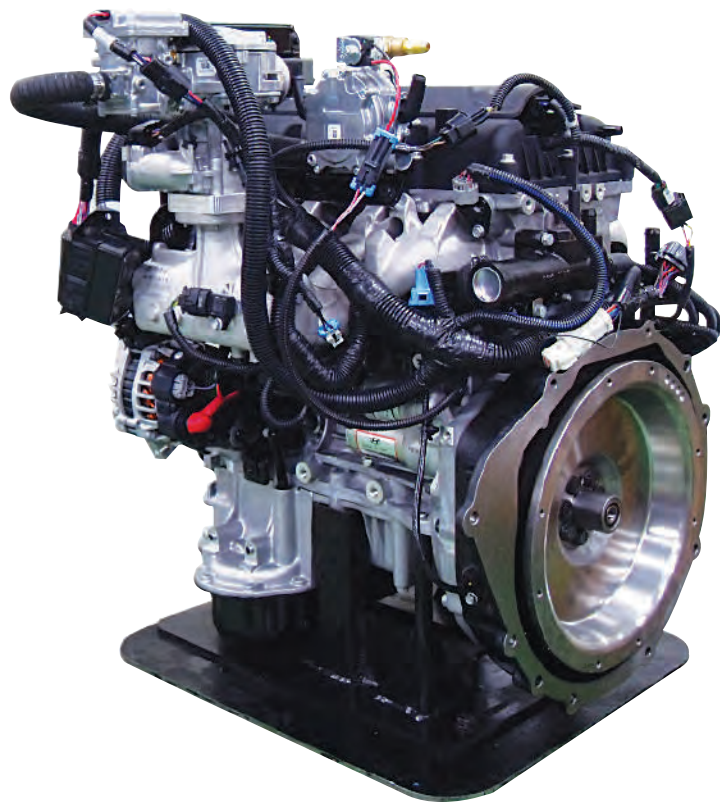

## Powerful Engine HMC L4KB(2.4L) Engine

Market approved quality of HMC L4KB engine ensures incomparable performance, durability and additional value to the machine. Powerful and efficient engine provides excellent fuel consumption and excellent torque. (EPA/CARB Tier-IV Certified)

**HMC L4KB(2.4L) Engine  
60PS (44.7kw)/2,300rpm**



**Oil cooled disc brake**

The semi-permanent wet disc brake provides constant braking force without overheating even when used for long hours of repetitive work, thus improving work efficiency.



**Highly durable drive axle**

A strong drive axle separate from the transmission ensures low vibration and easy maintenance. The wet disc brake system is virtually maintenance free and the enclosed design protects from dust and water.

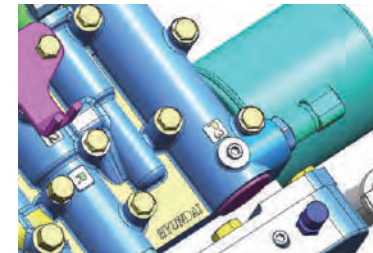

**Clutch protection system**

The clutch protection system warns of excessive use of inching as well as minimizing direction change impact.



**Fully hydrostatic power steering**

The hydraulic steering system guarantees smooth and flexible steering, preventing over-run and kick-back.



**Boosting type brake valve (OPT)**

Hydraulic assisted brakes provide strong, consistent brake performance.

## Faster Travel Speed & Gradeability

The powerful high-output engine provides greater acceleration, better gradeability and faster travel speed on any tough terrain or slope.

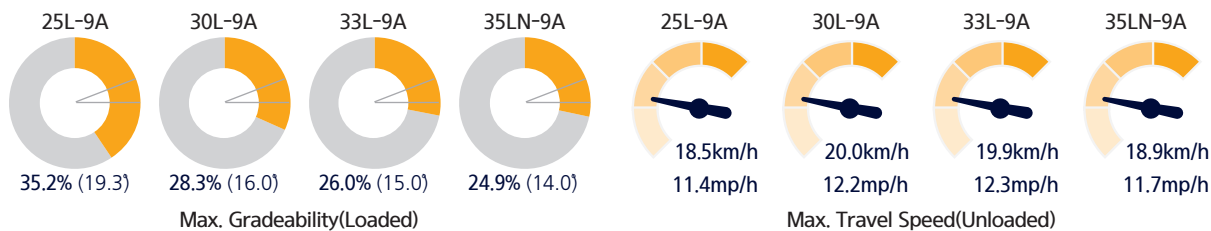



Easy & Comfort

# Best Convenience & Optimized Ergonomics

An efficient, comfortable workspace and compact design provides enhanced performance and outstanding productivity.

COMFORTABLE WORKSPACE

ADVANCED MONITORING SYSTEM

25L-9A

HYUNDAI

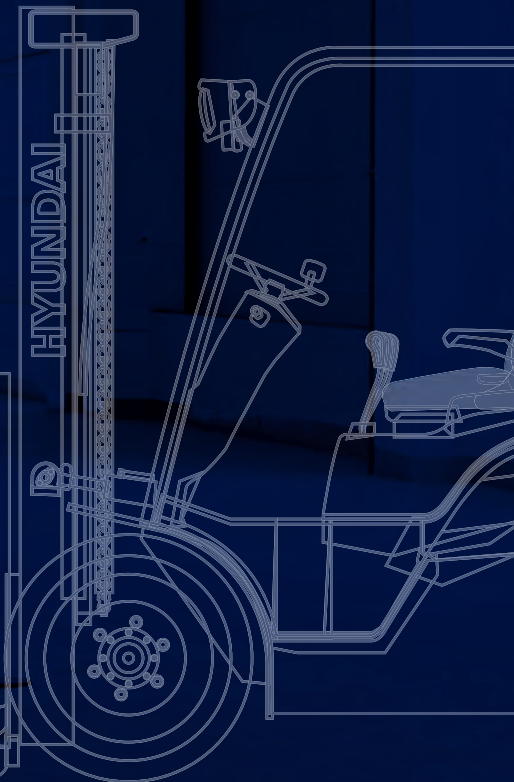

Some of the photos may include optional equipment.

## Spacious Operator Cabin

The newly designed cabin provides wide visibility and spacious environment, ensuring all day comfort for the operator.



Some of the photos may include optional equipment.



### Optimized pedal position

On the 9-series the pedals are mounted to the console to reduce operator fatigue, and noise and dust from the engine compartment.



### Adjustable steering wheel

The angle of the steering column can easily be adjusted to improve operator comfort.



### Fingertip

Ergonomically designed fingertip control levers eliminates reaches and awkward shoulder. It gives operators comfortability and efficiency.

### Grammer Seat (STD)

Easily adjustable suspension seat, based on a human engineering design, reduces operator fatigue and provides greater comfort.

- ELR(Emergency Locking Retractor) type seat belt as a standard
- Heating and head rest(OPT)



## Advanced LCD Monitor

The 5.6 inch wide screen LCD color monitor allows the operator to control the machine with ease. The monitor features speed, travel direction and hour meter.



### Main monitoring features

- Hour-meter
- Fuel level gauge (Warning-Red)
- Load weight indicator
- Machine inclination (Warning-Red)
- Signal / Warning light
- Gear (F / N / R)
- Speedometer
- Mast tilting degree (Alarm-Red)
- Clock
- Engine temperature gauge (Warning-Red)
- Machine inclination (Warning-Red)
- Odometer

### 1 Load Indicator

The optional load indicator displays the load weight on the monitor. The load sensor reduces the time to check loaded weight and the alarm alerts the driver when overloaded.

### 2 Auto Fork Leveling System (OPT)

To improve the productivity the auto fork leveling system will automatically stop the tilt movement when the mast is in a straight position.

### 3 Machine inclination indication

The grade (left) and slope (right) sensors are built into the MCU and provide the grade and slope status information of the vehicle connected with the road surface condition in real time.





Secure & Safety

# Excellent Visibility Advanced Safety

The safely designed driver's space makes your operator more comfortable.

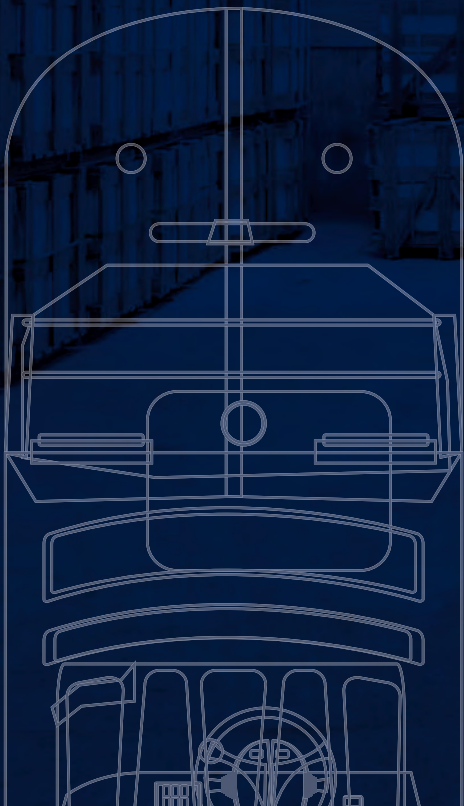

EXCELLENT VISIBILITY

ADVANCED SAFETY

Some of the photos may include optional equipment.

# Excellent Visibility for Safe Operation

Optimized lift cylinder arrangement provides operator with wider visibility. The panoramic mirror expands the driver's view when backing up.



**Safety lamps & rear reflectors**

LED headlights and rear LED combination lights offer the driver visibility in all circumstances. Rear reflectors mounted on the counterweight enhance safety for the driver and the application.



**Low entrance height**

The low entrance height ensures easy and safe access for the operator.



# Various Safety System

The adoption of a high-sensitivity sensor and advanced safety system decreases the risk of accidents.

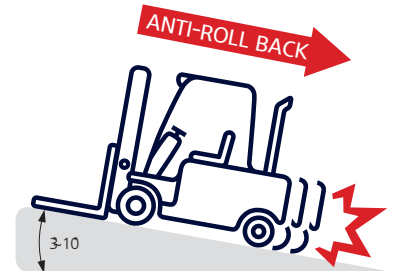

**Hill Start Assist Control (HAC)**

Anti Roll-back system offers protection against the machine rolling back on a ramp in combination with exceptional ramp start capabilities.

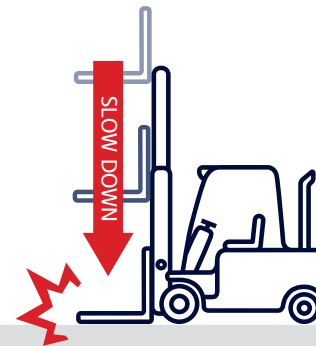

**Fork Safety Features**

As the forks are being lowered, a down-control valve maintains a controlled descent speed. The down-safety valve prevents forks from dropping down in case of sudden damage of hydraulic line.

**DRIVE LOCK | LIFT LOCK | TILT LOCK**



**Operator Presence Sensing System**

All mast and drive movements stop functioning when the operator is not in the seat.



**Strong overhead guard**

Exceeding CEE and ANSI regulations, the overhead guard offers optimal protection combined with excellent all round visibility.

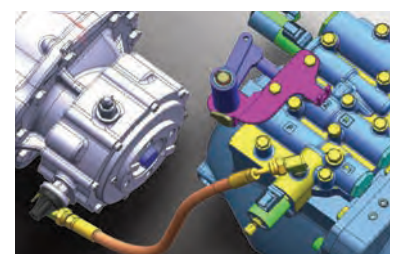

**Auto parking brake**

If the operator leaves the seat while the gear lever is in neutral, the parking brake is automatically engaged for safety, and released upon the operator's return to the seat.



Maintenance & Convenience

# Easy Maintenance & Various Convenience Devices

Ideal design for daily inspection and maintenance.  
High-quality convenience devices for operator  
Operator can work in the best conditions  
in any environment.

BEST CONVENIENCE

EASY MAINTENANCE

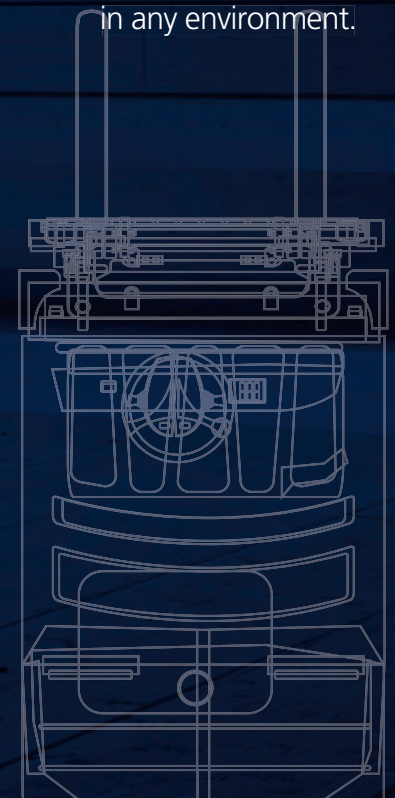

# Large Engine Hood

Highly accessible engine compartment assures fast and efficient maintenance. The enlarged air cleaner(7") has extended service time of engine.

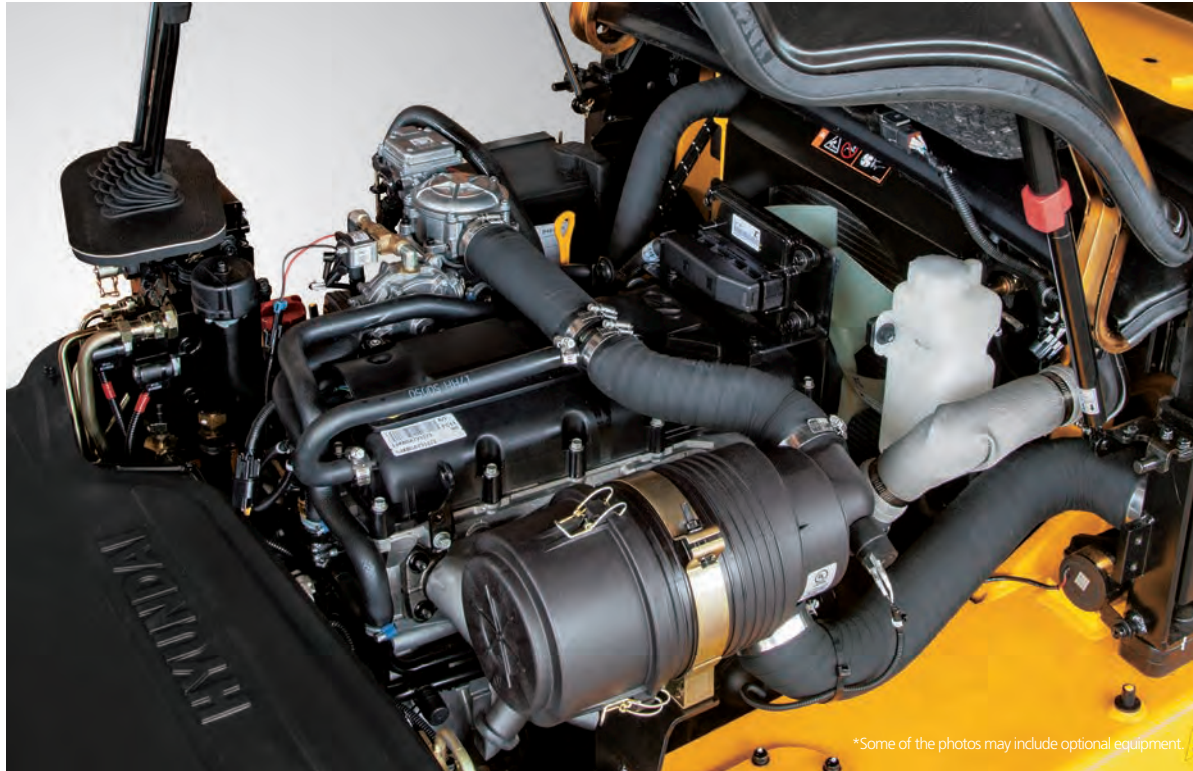

\*Some of the photos may include optional equipment.



**Waterproof & Dustproof cover**

Newly developed Waterproof and Dustproof fuse box and relay box for ease of maintenance.



**Rear tire & Under cover (OPT)**

The rear tire cover and under cover with PE material protect the engine, radiator, and components from operation site debris. Also, these options can be selected separately.



**Password starting system**

By granting the operation authority only to the designated driver, it is possible to manage the vehicle and prevent theft.



**Rear view camera (OPT)**

The rear view camera and monitor connected with the reverse switch helps to ensure a safe working environment.



**Parking brake switch (STD) & Emergency switch (OPT)**

A button-type switches enables to notify of emergency situations quickly and operate easily.



**Bolt on type cabin**

The bolt on type cabin consists of front side, door front, door rear, and rear side. It is easy to assemble by bolt and mount parts. Also, the cabin can be selected by module or parts and air conditioner and heater are separately available for the driver's comfort.

Maintenance Management			
Item	Interval	Elapse Count	Alarm
Axle Planetary Ge...	100	2 0	☑
Transmission Oil	100	2 0	☑
Transmission Oil F...	100	2 0	☑
Hydraulic Tank Ai...	250	2 0	☑
Air Cleaner Comp...	450	2 0	☑
Engine Oil Filter	500	2 0	☑

**Consumable item replacement cycle warning**

This indicator automatically alerts the operator of the replacement cycle of key consumable items before a failure occurs; making managing maintenance easy, and to help extend the life of the machine.



# New 9 Series Mast Specification

25L-9A



Mast Type		Maximum Fork Height		Overall Height (Lowered)		Free Lift Height				Tilt Angle		Load Capacity without side shift				Load Capacity with side shift				TRUCK WEIGHT (UNLOADED)			
						With Load Backrest		Without Load Backrest		Fwd	Bwd	Single Tire		Double Tire		Single Tire		Double Tire		Single Tire		Double Tire	
		in	mm	in	mm	in	mm	in	mm	deg	deg	24 in LC	500mm LC	24 in LC	500mm LC	24 in LC	500mm LC	24 in LC	500mm LC	24 in LC	500mm LC	lb	kg
2-STAGE LIMITED FREE LIFT	V300	118.3	3005	79.7	2025	4.5	155	4.5	155	6	10	5000	2500	5000	2500	5000	2500	5000	2500	8161	3702	8488	3850
	*V330	130.1	3305	85.6	2175	4.5	155	4.5	155	6	10	5000	2500	5000	2500	5000	2500	5000	2500	8203	3721	8532	3870
	V350	138.0	3505	89.6	2275	4.5	155	4.5	155	6	10	5000	2500	5000	2500	5000	2500	5000	2500	8241	3738	8569	3887
	V370	145.9	3705	95.5	2425	4.5	155	4.5	155	6	10	5000	2500	5000	2500	5000	2460	5000	2500	8267	3750	8598	3900
	V400	157.7	4005	101.4	2575	4.5	155	4.5	155	6	10	5000	2500	5000	2500	5000	2380	5000	2500	8355	3790	8684	3939
	V430	169.5	4305	107.3	2725	4.5	155	4.5	155	6	6	5000	2480	5000	2500	5000	2360	5000	2500	8470	3842	8799	3991
	V450	177.4	4505	113.2	2875	4.5	155	4.5	155	6	6	5000	2430	5000	2500	4870	2310	5000	2460	8519	3864	8847	4013
	V470	185.2	4705	117.1	2975	4.5	155	4.5	155	6	6	4960	2390	5000	2500	4740	2270	5000	2380	8552	3879	8878	4027
V500	197.0	5005	123.0	3125	4.5	155	4.5	155	6	6	4850	2330	5000	2430	4630	2210	5000	2310	8600	3901	8926	4049	
2-STAGE FULL FREE LIFT	VF295 / VS295	117.2	2976	79.7	2025	33.3	845	54.2	1377	6	6	5000	2500	5000	2500	5000	2500	5000	2500	8205	3722	8543	3875
	VF325 / VS325	129.0	3276	85.1	2175	38.7	995	60.2	1527	6	6	5000	2500	5000	2500	5000	2460	5000	2500	8278	3755	8618	3909
	VF345 / VS345	136.9	3476	89.6	2275	43.1	1095	64.1	1627	6	6	5000	2500	5000	2500	5000	2380	5000	2460	8331	3779	8688	3941
3-STAGE FULL FREE LIFT	TF370/TS370	145.9	3705	71.9	1825	25.4	645	46.3	1177	6	6	5000	2500	5000	2500	5000	2460	5000	2500	8404	3812	8743	3966
	TF400/TS400	157.7	4005	75.8	1925	29.3	745	50.3	1277	6	6	5000	2500	5000	2500	5000	2380	5000	2500	8457	3836	8796	3990
	TF430/TS430	169.5	4305	79.7	2025	33.3	845	54.2	1377	6	6	5000	2440	5000	2500	5000	2320	5000	2460	8496	3854	8836	4008
	TF450/TS450	177.4	4505	83.7	2125	37.2	945	58.1	1477	6	6	5000	2410	5000	2500	4850	2290	5000	2380	8545	3876	8884	4030
	TF470/TS470	185.2	4705	85.6	2175	39.2	995	60.1	1527	6	6	4920	2360	5000	2450	4700	2240	4860	2330	8576	3890	8913	4043
	TF500/TS500	197.0	5005	89.6	2275	43.1	1095	64.1	1627	6	6	4810	2310	4940	2400	4590	2190	4720	2280	8624	3912	8962	4065
	TF550/TS550	216.7	5505	97.4	2475	51.0	1295	71.9	1827	6	6	3240	1550	4780	2310	3020	1430	4560	2190	8710	3951	9048	4104
	TF600/TS600	236.4	6005	105.3	2675	58.9	1495	79.8	2027	6	6	2930	1400	4590	2210	2710	1280	4370	2090	8854	4016	9191	4169
	TF650/TS650	256.1	6505	113.2	2875	66.7	1695	87.7	2227	3	3	2840	1350	4540	2180	2620	1230	4320	2060	8955	4062	9295	4216
TF700/TS700	275.8	7005	121.1	3075	74.6	1895	95.6	2427	3	3	2430	1150	4370	2100	2210	930	4150	1980	9039	4100	9378	4254	
4-STAGE FULL FREE LIFT	QF610	240.7	6115	85.0	2160	38.6	980	59.5	1512	3	3	3200	1600	3400	1700	2960	1480	3160	1580	9387	4258	9771	4432
	QF660	260.4	6615	92.9	2360	46.5	1180	67.4	1712	3	3	2800	1400	3200	1600	2560	1280	2960	1480	9519	4318	9901	4491
	QF700	276.2	7015	96.9	2460	50.4	1280	71.3	1812	3	3	2200	1100	3000	1500	1960	980	2760	1380	9586	4348	9969	4522
	QF745	293.9	7465	102.8	2610	56.3	1430	77.2	1962	3	3	1600	800	2800	1400	1360	680	2560	1280	9687	4394	10071	4568
	QF790	311.6	7915	108.7	2760	62.2	1580	83.1	2112	3	3	1200	600	2400	1200	960	480	2160	1080	9907	4494	10291	4668

※ : Standard

30L-9A



Mast Type		Maximum Fork Height		Overall Height (Lowered)		Free Lift Height				Tilt Angle		Load Capacity without side shift				Load Capacity with side shift				TRUCK WEIGHT (UNLOADED)					
						With Load Backrest		Without Load Backrest		Fwd	Bwd	Single Tire		Double Tire		Single Tire		Double Tire		Single Tire		Double Tire			
		in	mm	in	mm	in	mm	in	mm	deg	deg	24 in LC	500mm LC	24 in LC	500mm LC	24 in LC	500mm LC	24 in LC	500mm LC	24 in LC	500mm LC	lb	kg	lb	kg
2-STAGE LIMITED FREE LIFT	V300	118.3	3005	80.3	2040	4.5	155	4.5	155	6	10	6000	3000	6000	3000	6000	3000	6000	3000	6000	3000	9030	4096	9303	4220
	*V330	130.1	3305	86.2	2190	4.5	155	4.5	155	6	10	6000	3000	6000	3000	6000	3000	6000	3000	6000	3000	9074	4116	9347	4240
	V350	138.0	3505	90.2	2290	4.5	155	4.5	155	6	10	6000	3000	6000	3000	6000	3000	6000	3000	6000	3000	9114	4134	9387	4258
	V370	145.9	3705	96.1	2440	4.5	155	4.5	155	6	10	6000	3000	6000	3000	6000	2930	6000	3000	6000	3000	9142	4147	9416	4271
	V400	157.7	4005	102.0	2590	4.5	155	4.5	155	6	6	6000	3000	6000	3000	6000	2820	6000	3000	6000	3000	9231	4187	9506	4312
	V430	169.5	4305	107.9	2740	4.5	155	4.5	155	6	6	6000	2960	6000	3000	6000	2780	6000	2950	6000	3000	9347	4240	9621	4364
	V450	177.4	4505	113.8	2890	4.5	155	4.5	155	6	6	6000	2920	6000	3000	5800	2740	6000	2825	6000	3000	9398	4263	9672	4387
	V470	185.2	4705	117.7	2990	4.5	155	4.5	155	6	6	5910	2850	6000	2930	5610	2670	5830	2755	6000	3000	9431	4278	9705	4402
V500	197.0	5005	123.6	3140	4.5	155	4.5	155	6	6	5820	2650	5970	2890	5520	2470	5670	2715	6000	3000	9482	4301	9755	4425	
2-STAGE FULL FREE LIFT	VF295 / VS295	117.2	2976	80.3	2040	33.9	860	51.7	1314	6	6	6000	3000	6000	3000	6000	3000	6000	3000	6000	3000	9173	4161	9444	4284
	VF325 / VS325	129.0	3276	85.1	2190	38.7	1010	60.2	1464	6	6	6000	3000	6000	3000	6000	2950	6000	3000	6000	3000	9250	4196	9522	4319
	VF345 / VS345	136.9	3476	90.2	2290	43.7	1110	61.6	1564	6	6	6000	3000	6000	3000	6000	2820	6000	2950	6000	3000	9328	4231	9599	4354
3-STAGE FULL FREE LIFT	TF370/TS370	145.9	3705	72.4	1840	26.0	660	43.9	1114	6	6	6000	3000	6000	3000	6000	2820	6000	3000	6000	3000	9414	4270	9685	4393
	TF400/TS400	157.7	4005	76.4	1940	29.9	760	47.8	1214	6	6	6000	3000	6000	3000	6000	2800	6000	2950	6000	3000	9469	4295	9738	4417
	TF430/TS430	169.5	4305	80.3	2040	33.9	860	51.7	1314	6	6	6000	2930	6000	3000	5810	2750	6000	2825	6000	3000	9517	4317	9786	4439
	TF450/TS450	177.4	4505	84.3	2140	37.8	960	55.7	1414	6	6	5930	2880	6000	2940	5630	2700	5830	2765	6000	3000	9572	4342	9843	4465
	TF470/TS470	185.2	4705	86.2	2190	39.8	1010	57.6	1464	6	6	5890	2850	5970	2900	5590	2670	5670	2725	6000	3000	9603	4356	9874	4479
	TF500/TS500	197.0	5005	90.2	2290	43.7	1110	61.6	1564	6	6	5730	2700	5840	2840	5430	2520	5540	2665	6000	3000	9654	4379	9923	4501
	TF550/TS550	216.7	5505	98.0	2490	51.6	1310	69.4	1764	6	6	3660	1750	5640	2720	3360	1570	5340	2545	6000	3000	9751	4423	10020	4545
	TF600/TS600	236.4	6005	105.9	2690	59.4	1510	77.3	1964	6	3	3020	1450	5450	2630	2720	1270	5150	2455	6000	3000	9905	4493	10174	4615
TF650/TS650	256.1	6505	113.8	2890	67.3	1710	85.2	2164	3	3	2930	1400	5380	2590	2630	1220	5080	2415	6000	3000	10018	4544	10287	4666	
TF700/TS700	275.8	7005	121.7	3090	75.2	1910	93.1	2364	3	3	2540	1200	5200	2500	2240	1020	4900	2325	6000	3000	10112	4587	10384	4710	
4-STAGE FULL FREE LIFT	QF610	240.7	6115	85.6	2175	39.2	995	57.0	1449	3	3	3400	1700	3600	1800	3040	1520	3240	1620	6000	3000	10317	4680	10628	4821
	QF660	260.4	6615	93.5	2375	47.0	1195	64.9	1649	3	3	3000	1500	3400	1700	2640	1320	3040	1520	6000	3000	10450	4740	10761	4881
	QF700	276.2	7015	97.4	2475	51.0	1295	68.9	1749	3	3	2400	1200	3200	1600	2040	1020	2840	1420	6000	3000	10516	4770	10827	4911
	QF745	293.9	7465	103.3	2625	56.9	1445	74.8	1899	3	3	1800	900	3000	1500	1440	720	2640	1320	6000	3000	10617	4816	10928	4957
QF790	311.6	7915	109.3	2775	62.8	1595	80.7	2049	3	3	1400	700	2600	1300	1040	520	2240	1120	6000	3000	10838	4916	11151	5058	

※ : Standard

# New 9 Series Mast Specification

33L-9A



Mast Type		Maximum Fork Height		Overall Height (Lowered)		Free Lift Height				Tilt Angle		Load Capacity without side shift				Load Capacity with side shift				TRUCK WEIGHT (UNLOADED)			
						With Load Backrest		Without Load Backrest		Fwd	Bwd	Single Tire		Double Tire		Single Tire		Double Tire		Single Tire		Double Tire	
		in	mm	in	mm	in	mm	in	mm	deg	deg	24 in LC	500mm LC	24 in LC	500mm LC	24 in LC	500mm LC	24 in LC	500mm LC	24 in LC	500mm LC	lb	kg
2-STAGE LIMITED FREE LIFT	V300	118.3	3005	83.1	2110	4.5	155	4.5	155	6	10	6500	3300	6500	3300	6500	3300	6500	3300	9636	4371	9923	4501
	*V330	130.1	3305	89.0	2260	4.5	155	4.5	155	6	10	6500	3300	6500	3300	6500	3300	6500	3300	9689	4395	9976	4525
	V350	138.0	3505	92.9	2360	4.5	155	4.5	155	6	10	6500	3300	6500	3300	6500	3300	6500	3300	9722	4410	10011	4541
	V370	145.9	3705	98.8	2510	4.5	155	4.5	155	6	10	6500	3300	6500	3300	6500	3210	6500	3300	9755	4425	10040	4554
	V400	157.7	4005	104.7	2660	4.5	155	4.5	155	6	10	6500	3300	6500	3300	6500	3120	6500	3300	9846	4466	10132	4596
	V430	169.5	4305	110.6	2810	4.5	155	4.5	155	6	6	6500	3250	6500	3300	6500	3070	6500	3250	9965	4520	10251	4650
	V450	177.4	4505	116.5	2960	4.5	155	4.5	155	6	6	6500	3190	6500	3300	6500	3010	6500	3125	10015	4543	10304	4674
	V470	185.2	4705	120.5	3060	4.5	155	4.5	155	6	6	6500	3140	6500	3240	6300	2960	6500	3065	10051	4559	10337	4689
2-STAGE FULL FREE LIFT	VF295 / VS295	117.2	2976	83.1	2110	36.6	930	54.5	1384	6	6	6500	3300	6500	3300	6500	3300	6500	3300	9819	4454	10099	4581
	VF325 / VS325	129.0	3276	88.3	2260	41.9	1080	60.1	1534	6	6	6500	3300	6500	3300	6500	3210	6500	3300	9899	4490	10179	4617
	VF345 / VS345	136.9	3476	89.0	2260	46.5	1180	64.3	1634	6	6	6500	3300	6500	3300	6500	3120	6500	3250	9976	4525	10254	4651
3-STAGE FULL FREE LIFT	TF370/TS370	145.9	3705	75.2	1910	28.7	730	43.9	1114	6	6	6500	3300	6500	3300	6500	3120	6500	3250	10135	4597	10414	4724
	TF400/TS400	157.7	4005	79.1	2010	32.7	830	47.8	1214	6	6	6500	3250	6500	3300	6500	3070	6500	3125	10183	4619	10463	4746
	TF430/TS430	169.5	4305	83.1	2110	36.6	930	51.7	1314	6	6	6500	3180	6500	3280	6500	3000	6500	3105	10229	4640	10509	4767
	TF450/TS450	177.4	4505	87.0	2210	40.6	1030	55.7	1414	6	6	6500	3120	6500	3220	6270	2940	6500	3045	10276	4661	10558	4789
	TF470/TS470	185.2	4705	89.0	2260	42.5	1080	57.6	1464	6	6	6350	3080	6500	3170	6050	2900	6290	2995	10306	4675	10586	4802
	TF500/TS500	197.0	5005	92.9	2360	46.5	1180	61.6	1564	6	6	6260	3030	6390	3110	5960	2850	6090	2935	10355	4697	10635	4824
	TF550/TS550	216.7	5505	100.8	2560	54.3	1380	69.4	1764	6	6	4560	2200	6170	2990	4260	2020	5870	2815	10452	4741	10732	4868
	TF600/TS600	236.4	6005	108.7	2760	62.2	1580	77.3	1964	6	6	3130	1500	5950	2870	2830	1320	5650	2695	10613	4814	10893	4941
TF650/TS650	256.1	6505	116.5	2960	70.1	1780	85.2	2164	3	3	3060	1450	5910	2830	2760	1280	5610	2655	10719	4862	10999	4989	
TF700/TS700	275.8	7005	124.4	3160	78.0	1980	93.1	2364	3	3	2650	1250	5710	2730	2350	1080	5410	2555	10809	4903	11089	5030	
4-STAGE FULL FREE LIFT	QF610	240.7	6115	87.6	2225	41.1	1045	57.0	1449	3	3	3600	1800	3800	1900	3240	1620	3440	1720	10891	4940	11182	5072
	QF660	260.4	6615	95.5	2425	49.0	1245	64.9	1649	3	3	3200	1600	3600	1800	2840	1420	3240	1620	11023	5000	11314	5132
	QF700	276.2	7015	99.4	2525	53.0	1345	68.9	1749	3	3	2600	1300	3400	1700	2240	1120	3040	1520	11089	5030	11380	5162
	QF745	293.9	7465	105.3	2675	58.9	1495	74.8	1899	3	3	2000	1000	3200	1600	1640	820	2840	1420	11184	5073	11475	5205
	QF790	311.6	7915	111.2	2825	64.8	1645	80.7	2049	3	3	1600	800	2800	1400	1240	620	2440	1220	11411	5176	11704	5309

※ : Standard

35LN-9A



Mast Type		Maximum Fork Height		Overall Height (Lowered)		Free Lift Height				Tilt Angle		Load Capacity without side shift				Load Capacity with side shift				TRUCK WEIGHT (UNLOADED)			
						With Load Backrest		Without Load Backrest		Fwd	Bwd	Single Tire		Double Tire		Single Tire		Double Tire		Single Tire		Double Tire	
		in	mm	in	mm	in	mm	in	mm	deg	deg	24 in LC	500mm LC	24 in LC	500mm LC	24 in LC	500mm LC	24 in LC	500mm LC	24 in LC	500mm LC	lb	kg
2-STAGE LIMITED FREE LIFT	V300	118.3	3005	83.1	2110	4.5	155	4.5	155	6	10	7000	3500	7000	3500	7000	3500	7000	3500	9946	4511	10129	4594
	*V330	130.1	3305	89.0	2260	4.5	155	4.5	155	6	10	7000	3500	7000	3500	7000	3500	7000	3500	9998	4535	10181	4618
	V350	138.0	3505	92.9	2360	4.5	155	4.5	155	6	10	7000	3500	7000	3500	7000	3440	7000	3500	10033	4551	10216	4634
	V370	145.9	3705	98.8	2510	4.5	155	4.5	155	6	10	7000	3500	7000	3500	6890	3390	7000	3460	10085	4575	10268	4658
	V400	157.7	4005	104.7	2660	4.5	155	4.5	155	6	10	7000	3500	7000	3500	6730	3310	6860	3380	10156	4607	10339	4690
	V430	169.5	4305	110.6	2810	4.5	155	4.5	155	6	6	6950	3420	7000	3500	6580	3230	6710	3300	10274	4660	10457	4743
	V450	177.4	4505	116.5	2960	4.5	155	4.5	155	6	6	6850	3370	7000	3470	6470	3180	6620	3250	10326	4684	10509	4767
	V470	185.2	4705	120.5	3060	4.5	155	4.5	155	6	6	6750	3310	6930	3420	6380	3130	6530	3200	10361	4700	10544	4783
2-STAGE FULL FREE LIFT	VF295 / VS295	117.2	2976	83.1	2110	36.6	930	54.5	1384	6	6	7000	3500	7000	3500	7000	3500	7000	3500	10129	4595	10306	4675
	VF325 / VS325	129.0	3276	89.0	2260	41.9	1080	60.1	1534	6	6	7000	3500	7000	3500	7000	3460	7000	3500	10207	4630	10383	4710
	VF345 / VS345	136.9	3476	92.9	2360	46.5	1180	64.3	1634	6	6	7000	3500	7000	3500	6900	3400	7000	3460	10284	4665	10459	4744
3-STAGE FULL FREE LIFT	TF370/TS370	145.9	3705	75.2	1910	28.7	730	43.9	1114	6	6	7000	3500	7000	3500	6750	3320	6860	3390	10443	4737	10620	4817
	TF400/TS400	157.7	4005	79.1	2010	32.7	830	47.8	1214	6	6	6950	3440	7000	3500	6600	3240	6730	3320	10492	4759	10668	4839
	TF430/TS430	169.5	4305	83.1	2110	36.6	930	51.7	1314	6	6	6820	3360	7000	3460	6460	3170	6600	3250	10538	4780	10714	4860
	TF450/TS450	177.4	4505	87.0	2210	40.6	1030	55.7	1414	6	6	6710	3310	6890	3410	6380	3120	6510	3200	10586	4802	10762	4882
	TF470/TS470	185.2	4705	89.0	2260	42.5	1080	57.6	1464	6	6	6620	3260	6800	3360	6290	3080	6420	3160	10615	4815	10792	4895
	TF500/TS500	197.0	5005	92.9	2360	46.5	1180	61.6	1564	6	6	6490	3190	6670	3290	6160	3010	6290	3090	10665	4838	10842	4918
	TF550/TS550	216.7	5505	100.8	2560	54.3	1380	69.4	1764	6	6	4820	2340	6450	3170	4490	2190	6070	2980	10762	4882	10938	4962
	TF600/TS600	236.4	6005	108.7	2760	62.2	1580	77.3	1964	6	6	3100	1500	6230	3060	2810	1360	5870	2870	10921	4954	11098	5034
TF650/TS650	256.1	6505	116.5	2960	70.1	1780	85.2	2164	3	3	2860	1380	6000	2950	2570	1240	5670	2770	11029	5003	11205	5083	
TF700/TS700	275.8	7005	124.4	3160	78.0	1980	93.1	2364	3	3	2570	1240	5800	2850	2280	1090	5500	2680	11118	5043	11294	5123	
4-STAGE FULL FREE LIFT	QF610	240.7	6115	87.6	2225	41.1	1045	57.0	1449	3	3	3800	1900	4000	2000	3440	1720	3560	1780	11200	5080	11388	5165
	QF660	260.4	6615	95.5	2425	49.0	1245	64.9	1649	3	3	3400	1700	3800	1900	3040	1520	3360	1680	11333	5141	11521	5226
	QF700	276.2	7015	99.4	2525	53.0	1345	68.9	1749	3	3	2800	1400	3600	1800	2440	1220	3160	1580	11398	5170	11586	5256
	QF745	293.9	7465	105.3	2675	58.9	1495	74.8	1899	3	3	2200	1100	3400	1700	1840	920	2960	1480	11492	5213	11680	5298
QF790	311.6	7915	111.2	2825	64.8	1645	80.7	2049	3	3	1800	900	3000	1500	1440	720	2560	1280	11721	5317	11909	5402	

※ : Standard

# New 9 Series

## Load Capacity

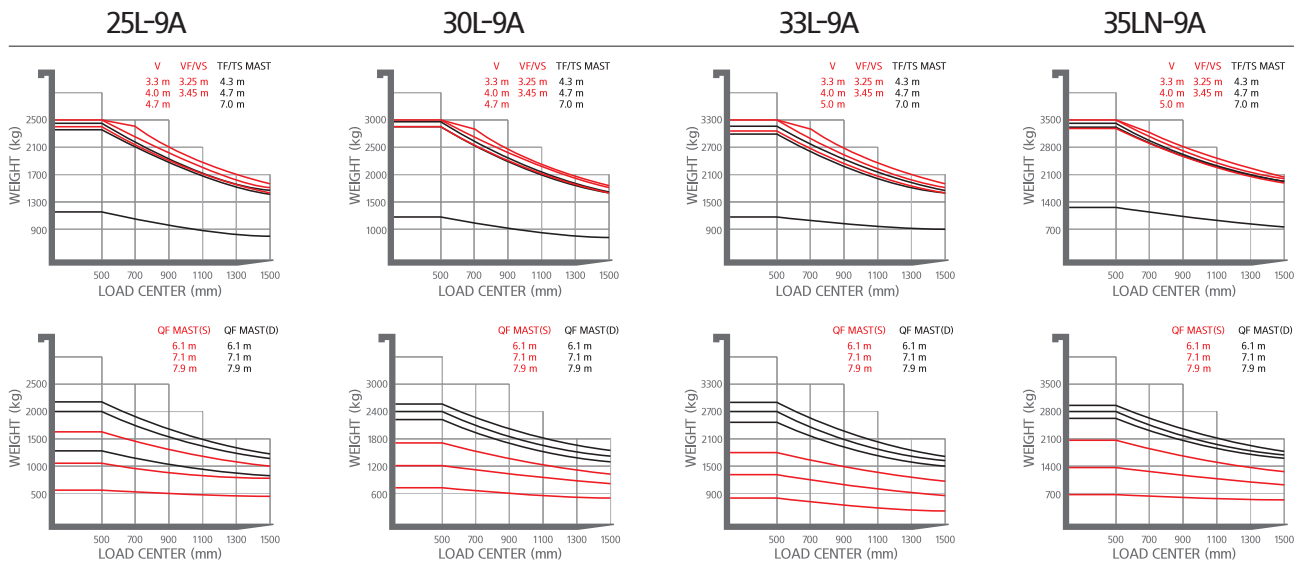

## Optional Items

- Fork(mm)
  - 25L-9A : 900, 1000, 1050(STD), 1200, 1350, 1500, 1650, 1800, 2100
  - 30/33L-9A, 35LN-9A : 900, 1050(STD), 1150, 1200, 1650, 1800, 1970, 2120, 2300, 2400
- Integral Sideshift, Fork Positioner, Sideshift
- Integral Fork Positioner with Sideshift
- Tire : Solid (superelastic) / Non-marking / Front double tire
- M.C.V : 4-Spool
- Seat : Heat, Backrest Ext, Buckle SW
- Auto Fork Leveling System
- Rear View Camera
- Cabin(Heater, A/C)
- Hydraulic Pump Temperature / Pressure Indication
- Beacon Lamp(LED) (Amber, Red, Blue)
- Rear work Lamp(Bulb or LED)
- F-N-R & Horn Knob switch
- Finger Tip Control Lever

## Attachments

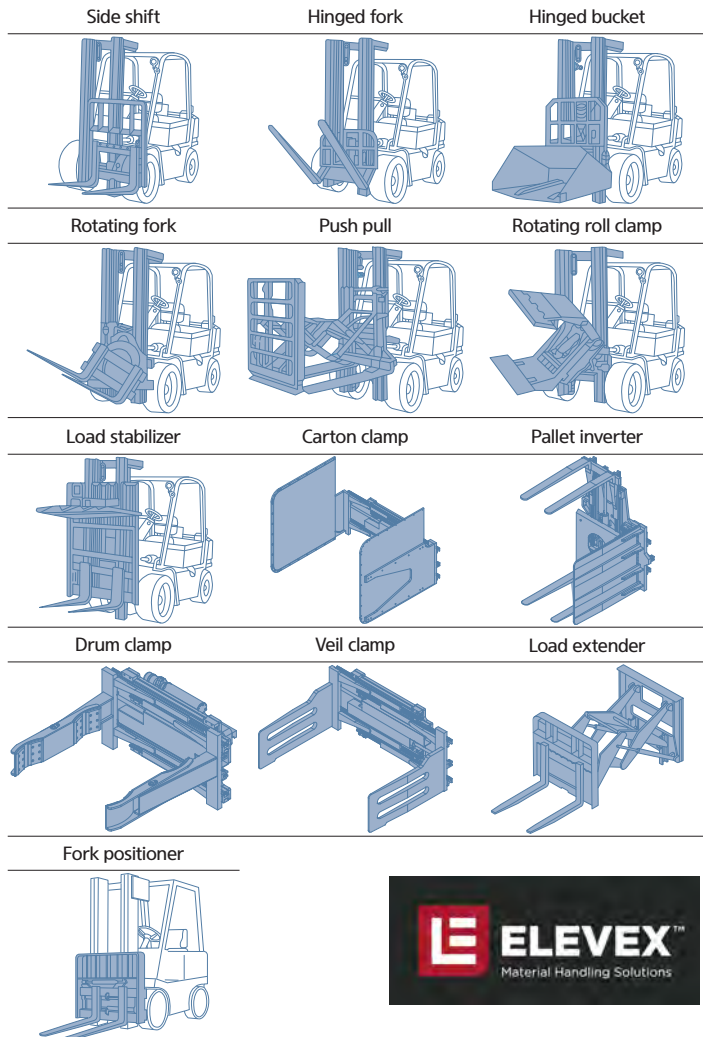

\* All specifications and photos in this catalog are subject to change for quality improvement.

## Specification



Identification		Hyundai				
1.1	Manufacturer	Hyundai				
1.2	Manufacturer's model designation	25L-9A	30L-9A	33L-9A	35LN-9A	
1.3	Drive: electric (battery or mains),diesel,petrol,fuel gas,manual	LPG	LPG	LPG	LPG	
1.4	Type of operation:hand,pedestrian,standing,seated,order-picker	seated	seated	seated	seated	
1.5	Load capacity / Rated load	5000/2500	6000/3000	6500/3300	7000/3500	
1.6	Load center distance	24/500	24/500	24/500	24/500	
1.8	Load distance, center of drive axle to fork	18.5/468	18.5/468	18.5/468	18.5/468	
1.9	Wheelbase	65/1650	67/1700	67/1700	67/1700	
<b>Weights</b>						
21	Service weight	8,203/3,721	9,074/4,116	9,689/4,395	9,998/4,535	
22	Axle loading, loaded front - rear	12,273-1,812/5,491-731	14,054-1,997/6,298-818	15,007-2,323/6,727-968	15,304-2,407/6,342-1,092	
23	Axle loading, unloaded front - rear	3,527-5,044/1,524-2,197	3,675-5,765/1,590-2,526	3,589-6,466/1,548-2,847	3,194-6,801/1,449-3,085	
<b>Wheels, Chassis</b>						
3.1	Tires : Pneumatic(P), Solid(S), Non-marking(N)	P	P	P	P	
3.2	Tires size, rear	Single	7.00-12-12PR	8.15-15-14PR	8.15-15-14PR	8.15-15-14PR
		Double	6.00-15-10PR	6.00-15-10PR	6.00-15-10PR	6.00-15-10PR
3.3	Tires size, rear	6.50-10-12PR				
3.4	Number of wheels front / rear (x=driven wheels)	2x / 2		2x / 2		
3.5	Track width (front)	Single in/mm	39/999	39.5/1,005	39.5/1,005	39.5/1,005
		Double in/mm	45/1,153	45/1,153	45/1,153	45/1,153
		in/mm	38.5/980	38.5/980	38.5/980	38.5/980
<b>Dimensions</b>						
4.1	Mast / fork carriage tilt forward / backward	degrees	6 / 10	6 / 10	6 / 10	6 / 10
4.2	Lowered mast height	h1 in/mm	85.6/2,175	86/2,190	89/2,260	89/2,260
4.3	Free lift height	h2 in/mm	6/155	6/155	6/155	6/155
4.4	Lift Height	h3 in/mm	130/3,305	130/3,305	130/3,305	130/3,305
4.5	Extended mast height	h4 in/mm	176.5/4,485	176.5/4,485	176.5/4,485	176.5/4,485
4.7	Overhead guard (cab) height	h5 in/mm	85 (85.5) / 2,160 (2,170)	85.8 (86.2) / 2,180 (2,190)	85.8 (86.2) / 2,180 (2,190)	85.8 (86.2) / 2,180 (2,190)
4.8	Seat height / Standing height	h7 in/mm	46.7/1,187	47.7/1,212	47.7/1,212	47.7/1,212
4.12	Coupling height	h10 in/mm	11.6/295	12.5/320	12.5/320	12.5/320
4.19	Overall length	l1 in/mm	144/3,657	146.7/3,726	148.9/3,782	148.9/3,782
4.20	Length to face of forks	l2 in/mm	102.6/2,607	105.3/2,676	107.5/2,732	108.5/2,757
4.21	Overall Width	Single b1 in/mm	47/1,200	48.3/1,228	48.3/1,228	48.3/1,228
		Double b1 in/mm	59.7/1,517	59.7/1,517	59.7/1,517	59.7/1,517
4.22	Fork dimensions(hook type)	in/mm	41.3x3.9x1.7/1,050x100x45	41.3x4.8x1.7/1,050x122x45	41.3x4.8x1.7/1,050x122x45	41.3x4.8x1.7/1,050x122x45
4.23	Fork carriage ISO 2328, class / type A, B		IIA	IIIA	IIIA	IIIA
4.24	Fork - carriage width	b3 in/mm	43.3/1,102	43.3/1,102	43.3/1,102	43.3/1,102
4.31	Minimum ground clearance (mast)	m1 in/mm	5/130	5.7/145	5.7/145	5.7/145
4.32	Minimum ground clearance (center of wheelbase)	m2 in/mm	6/157	7/181	7/181	6.7/171
4.33	Aisle Width For Pallets 1000 x 1200 Crossways (LxW)	Ast in/mm	157.8/4,010	160.6/4,081	170.5/4,331	170.5/4,331
4.34	Aisle Width Of Pallets 800 x 1200 Lengthways (W L)	Ast in/mm	165.7/4,210	168.5/4,281	170.5/4,331	170.5/4,331
4.35	Minimum turning radius	Wa in/mm	92/2,342	95/2,413	96.9/2,463	98/2,490
4.36	Smallest pivot point distance	b13 in/mm	28/714	28.7/731	28.7/731	28.7/731

Performance Data						
5.1	Travel speed, unloaded	mph/kmh	11.5/18.5	12.4/19.9	12.3/19.7	11.7/18.8
5.2	Lift speed, loaded/unloaded	inch per s	22.8/23.2	22.4/23.2	18.1/18.9	17.7/18.9
		mm per s	580/590	570/590	460/480	450/480
5.3	Lowering speed, loaded/unloaded	inch per s	19.7/17.7	19.7/17.7	19.7/17.7	19.7/17.7
		mm per s	500 / 450	500 / 450	500 / 450	500 / 450
5.5	Drawbar pull, loaded	lb/kg	5,921.6/2,286	5,372.6/2,437	5,385.9/2,443	
5.7	Gradient performance, loaded	%	35.2	28.3	26.0	24.9
5.9	Acceleration time, loaded/ unloaded(10m)	sec	-	-	-	-
5.10	Service brake		FOOT	FOOT	FOOT	FOOT
<b>Engine</b>						
6.1	Engine manufacturer / type		HMC/L4KB	HMC/L4KB	HMC/L4KB	HMC/L4KB
6.2	Engine power acc. to ISO 1585	hp/kW@rpm	60/44.1@2300	60/44.1@2300	60/44.1@2300	60/44.1@2300
6.3	Maximum Torque	lbf ft/kgf.m@rpm	137/19@1800	137/19@1800	137/19@1800	137/19@1800
6.4	No. of cylinder / cubic capacity	EA/cc	4/2,359	4/2,359	4/2,359	4/2,359
6.5	Fuel consumption acc. To VDI cycle	ℓ/h	-	-	-	-
<b>Other Details</b>						
8.1	Type of drive control		PowerShift	PowerShift	PowerShift	PowerShift
8.2	Operating pressure, system / attach	psi	2,843/2,450	2,988/2,450	2,988/2,450	3,132/2,450
		bar	196/162	206/162	206/162	216/162
8.3	Oil volume (hydraulic)	ℓ	30(60 Max.)	30(60 Max.)	30(60 Max.)	30(60 Max.)
8.4	Sound pressure level (at driver's ear according to DIN 12053)	dB(A)	80	80	80	80
8.5	Trailer coupling, type DIN		PIN	PIN	PIN	PIN

## Dimension

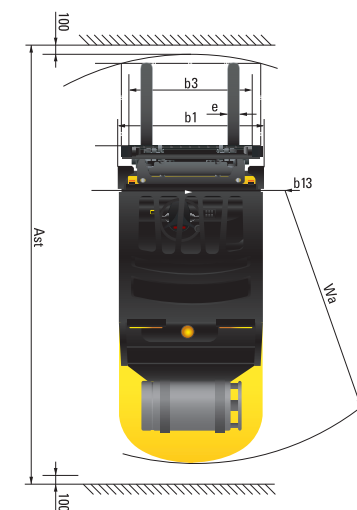
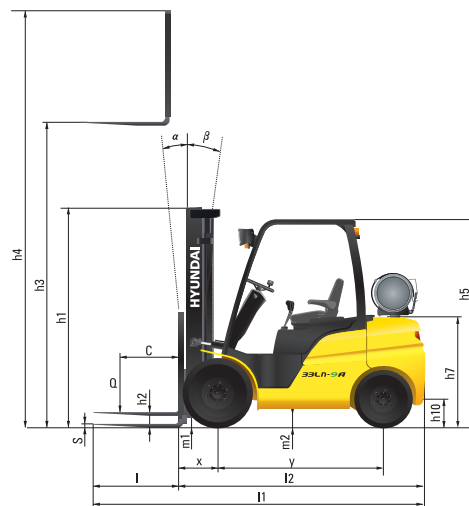

\* All specifications in this catalog are subject to change according to the optional items.



**MONTREAL (Head office)**

100A, Hymus Blvd.  
Pointe-Claire (Québec) H9R 1E4  
Phone: 514 694-4223  
Toll free: 1 866 421-4223  
info@elevex.ca

**SAGUENAY**

2305, Alexis-Le-Trotteur Street  
Jonquière (Québec) G7X 9H8  
Phone : 418 543-0000  
Toll free: 1 866 421-4223