



35·40·45

50L-9



Some of the photos may include optional equipment.

Moving You Further



Your Satisfaction is our Priority!

Internal Combustion LPG Engine Forklift 35/40/45/50L-9 Series

Having produced equipment with proven durability, and high reliability for a wide range of customers and environments for many years, Hyundai Material Handling introduces our new LPG forklift line that is eco-friendly and cost-effective in the 3.5 to 5 metric ton class, with improved fuel consumption rates and performance capabilities while satisfying EPA, CARB, and EU Stage V Emission Certifications.

Environmentally Friendly

- Satisfies Euro Stage 5, EPA, and CARB, while reducing fuel consumption

Productivity & Durability

- Dramatic reduction in Total Cost of Ownership: Optimized engine, reducing loads on the cooling and hydraulic systems

→ Fuel consumption rate improved by 7% (VDI 2198)

- Increased travel speeds and improved traction power: Through the application of a new transmission and drive axle
 - * Transmission durability improved: Improved clutch pack power transfer by 25%, increased transmission oil volume by 4.23 qts
- Prolonged service life of wet-type disk brake system: Drive axle oil volume increased by 2.6 quarts
- Wheel base extended: Improved traveling stability and increased hydraulic system capacity on L45-9 and L50-9 units

Enhanced Safety

- Auto Parking brake: Automatically activated when engine is OFF or OPSS (Operator Presence Sensing System) is activated
- Restriction of drive, lift, and tilt functions while the operator is not in the seat (standard)
- Load weight indicator (standard)
- System operation stopped when the seat belt is not worn (optional)
- Governable max travel speed (standard)

Outstanding Operability (Ergonomics)

- Equipment status is easily observed via the new digital cluster
- Steering wheel diameter reduced and Danfoss 4th-generation Obitrol installed: Steering capability increased, while reducing noise, and improving steering feel
- Deluxe Grammer Suspension Seat: Adjustable cushion w/ Emergency Locking Retractor (ELR) seat belt
- Directional Travel & Horn Switch installed on 1st hydraulic function handle: Convenient operation and response to emergency situations (optional)
- Bolt on Type Deluxe Cabin, Air Conditioning, and Heater (optional)

Ease of Service

- Equipped with a standalone 3-way catalytic converter: Saving on follow-up maintenance costs
- Multi-function Cluster: Alerting operator to service intervals and equipment fault codes
- Mounting orientation of Hydraulic MCV (Main Control Valve) allows for ease of maintenance and quick access to the Integrated Emergency lowering valve & flow regulator
- IP 67 Rated class fuse & relay box: Preventing contamination caused by dust and moisture
- Low Fuel Indicator (standard)





Environmentally Friendly, Great Productivity, & Proven Durability



Some of the photos may include optional equipment.



Eco-Friendly Kubota WG3800 LPG engine

The Kubota WG3800 engine has been developed based on the excellent durability of their diesel engine, satisfying EPA, CARB, and Euro Stage V emission regulations. Engine noise is reduced, and fuel consumption rate is optimized. Post-treatment of exhaust gases are handled via a Catalytic Converter System. The compact design of the engine allows for more space in the engine compartment, increasing ease of service.

Displacement : 3,769cc (4cyl)
91hp @ 2,300rpm
214ft-lbs @ 1,200rpm

Optimized Fuel Consumption

Fuel efficiency

7% ↑

The advantages of the engine include: Optimized engine displacement and power; uniform torque throughout the rpm range; decreased cooling system load; and improved fuel consumption (VDI mode) by 7% (VDI 2198) compared to competitor products.

Driving Performance

Travel speed **24%** ↑
 Drawbar pull **5.3%** ↑

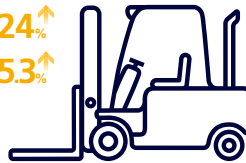

Maximum travel speed and drawbar pull have increased by 24% and 5.3% respectively, by resetting the high-speed RPM range of the engine and installation of the new Hyundai Genuine transmission and drive axle.

▲ HYUNDAI GENUINE New Transmission & Drive axle



F2/R1 - Transmission

Power transfer capability of clutch pack increased by 25% and transmission oil volume increased 4.2 qts. Accounting for continuous work environments, the reverse gear is engineered in a stand alone configuration to enhance durability and practicality. The transmission's DCSR controller prevents failure of internal gear train caused by impacts that are generated by changing the traveling direction between forward and reverse without stopping vehicle travel (Plugging).



Drive Axle

The planetary final reduction gear system is perfect for applications where significant torque variations are needed; oil sump capacity is designed to be larger for rapid absorption and emission of braking heat. Maintenance-free auto parking system is internally mounted to the input shaft of the differential assembly.



Auto Shifting System

A transmission control program is incorporated into the digital cluster for automatic gear shifting of the first and second gears depending on the rotation rate of transmission-output shaft to prevent premature wear of transmission components caused by forced take-off in second gear.



Oil-Cooled Disc Brakes

Equipped with a wet-type braking system for prolonged service life, designed with an increased drive axle oil capacity for the rapid cooling of heat generated from braking, ensures uniform braking capability, reduced wear, and prolonged service life.



4.5/5.0ton : 3.9in, (2,100mm)

Increased Wheel Base – 4.5/5.0t

The heavy-duty wheel base of the 45L-9 and 50L-9 is extended by 3.9in (2,100mm) to improve travel stability and work load safety; increasing the service life of the steer tires, and the reliability of the steering system. In addition, the hydraulic oil tank capacity has been increased to reduce the effects of heat on the hydraulic system, further reducing wear and tear.



Enhanced Safety

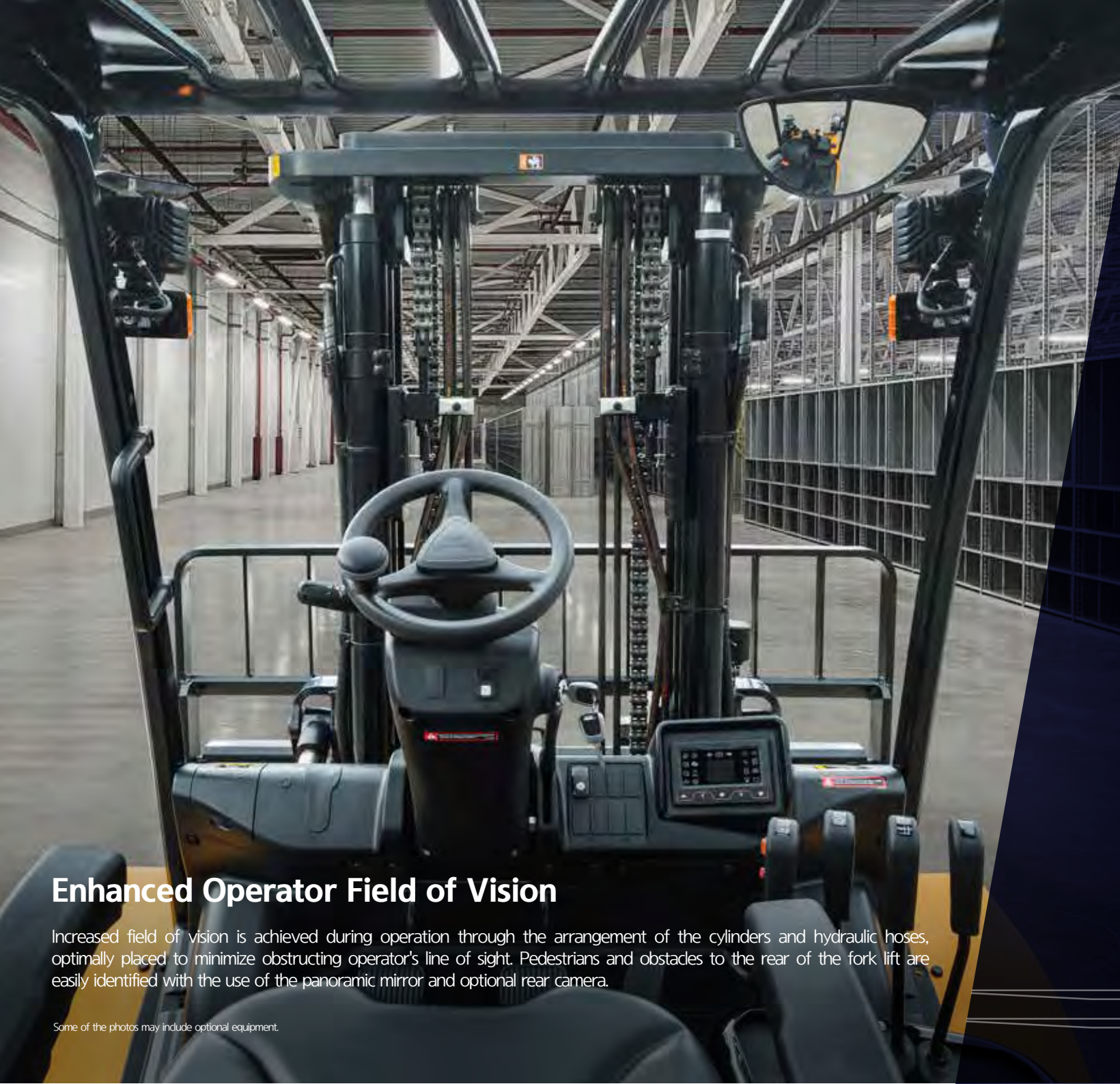

Enhanced Operator Field of Vision

Increased field of vision is achieved during operation through the arrangement of the cylinders and hydraulic hoses, optimally placed to minimize obstructing operator's line of sight. Pedestrians and obstacles to the rear of the fork lift are easily identified with the use of the panoramic mirror and optional rear camera.

Some of the photos may include optional equipment.

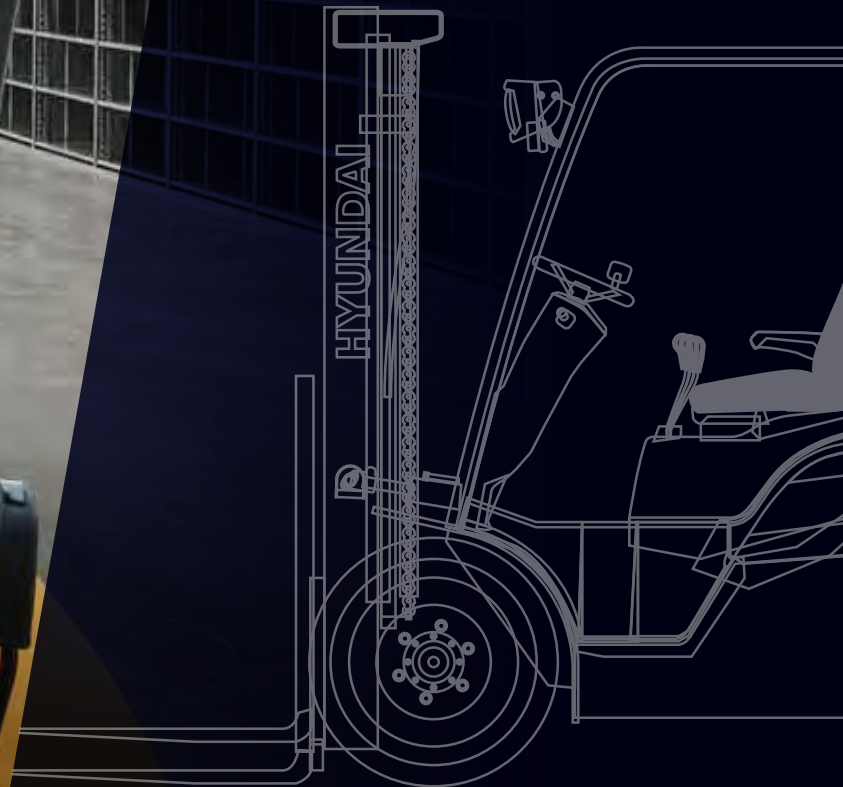



LED Lamps

LED lighting includes headlamps, rear work lamps, and combination lamps. LED lamps provide extended service life and higher visibility in dark work areas.



Password Starting System

Use of the password function on the cluster, capable of storing up to ten passwords, prevents unauthorized personnel from starting and operating the forklift. Reducing the risk of accidents, damage, and theft of the forklift. (OPT)



Load Indicator (OPT)

The optional load indicator displays load weight and prompts a warning on the cluster in case of exceeding max capacity to remind the operator of safe operational limits. (Not for legal trade)

Various Safety Systems

The use of multiple safety sensors and advanced safety features reduce the risks of accidents and injuries in the work place.

DRIVE LOCK LIFT LOCK TILT LOCK



OPSS

The Operator Presence Sensing System (OPSS) renders all mast and drive functions inoperable when the operator isn't in the seat.



Auto Parking

In the event that the operator leaves the seat while the gear selector is in neutral, the parking brake is automatically engaged to ensure safety, and is released once the operator returns to the seat.

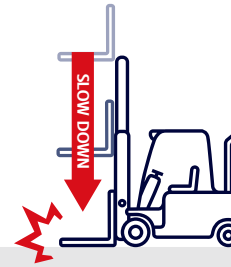

Fork Safety Features

A down-control valve maintains a controlled descent speed, while the down-safety valve prevents the load from falling in the case of sudden damage to a hydraulic line.



Speed Limit

Adjustable max travel speed limits to increase safety based on operation environment.

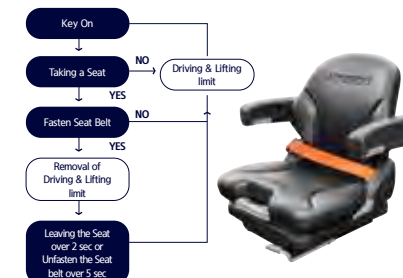

Seatbelt Interlock(OPT)

Forklift will not operate if the seatbelt is not fastened. Intentionally unfastening the seatbelt during operation safely shuts the forklift down. This system protects the operator from accidents and injuries that may take place when the seat belt is not worn.



Outstanding Operability

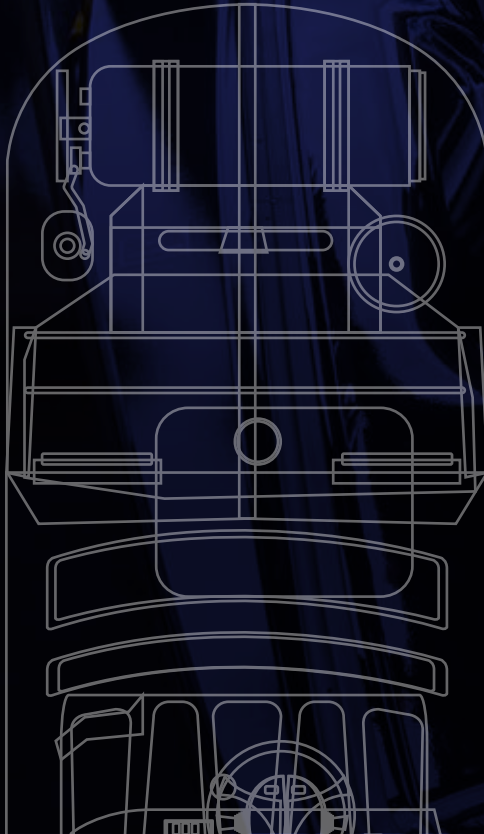

Ergonomic Operator Compartment

This is a space where safety and productivity are ensured at the worksite. An ergonomic design concept has been applied to maximize the convenience and operability of all functional controls. The Grammer Full Suspension Seat provides comfort during extended work periods, reducing operator fatigue, and increasing productivity.

Some of the photos may include optional equipment.



Multifunction Digital Cluster

The driver is able to check the operational status in real time on the multifunction digital cluster. Designed to ensure the visibility of important information during operation, and the standard Low Fuel alarm and lamp prevents the unintended shutdown of equipment operation. In addition, various additional functions are accessible through the cluster for safe and convenient equipment management.

- Major additional functions: Tracking of Service Intervals, Fault Codes, and display of Load Weight.

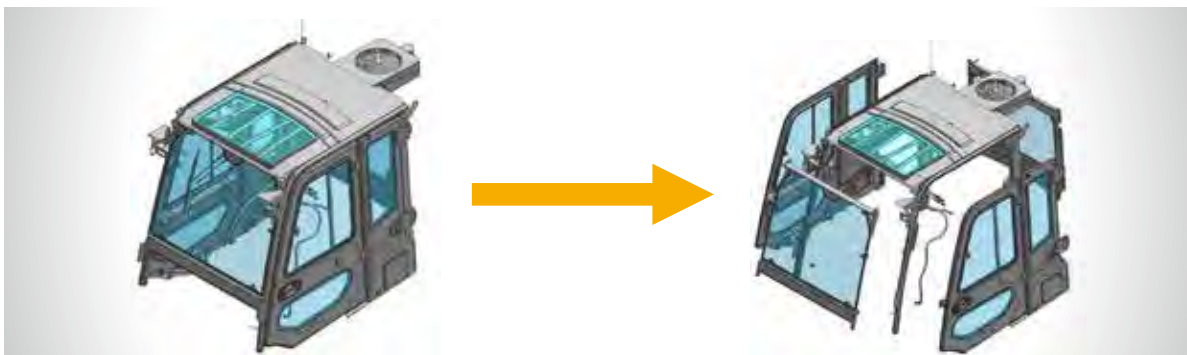

Deluxe Cabin, Air Conditioning and Heater (OPT)

The bolt-on type cabin consists of four components: Front glass, roof, side door, and rear glass, which can be installed and replaced with original parts easily and cost-effectively. Cabin is available complete or as separate parts. Air-conditioner and heater are individually available as well for a climate controlled operating environment.



Grammer Seat (STD)

Easily adjustable, full suspension seat reduces operator fatigue and provides greater comfort.

Emergency Locking Retractable type seatbelt.

Seat belt switch, arm rests, and heater (OPT)



Directional & Horn Switch on Lever (OPT)

An optional directional control and secondary horn switch can be mounted to the first hydraulic function lever for quick and precise directional control and reduced operator fatigue. The position of the horn button provides quick access if needed.



Auto Tilting (OPT)

When using this option during tilt operation, the forks automatically stop at a position parallel to the ground. This function enhances safety and productivity when loading and unloading pallets on and off of racking at high elevation.

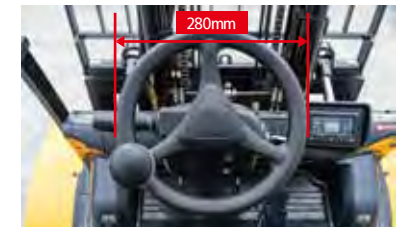

Steer Handle

The diameter of the steering wheel is reduced by 1.6" for better ergonomics and to reduce operator fatigue. Furthermore, employing new steering components lends itself to a lighter feeling steering wheel, optimal turning function preventing jamming, and noise that result during tight or quick handling maneuvers.



Rear Grab Handle w/ Horn Button (STD)

Allows the driver to keep a stable, convenient posture while operating in reverse, ensuring their hand remains inside the OHG, and granting them the ability to operate the horn quickly without changing their driving posture.



Easy and Cost-Effective Follow-Up Management

Large Maintenance Space

A large work space is provided for the servicing of the powertrain and major functional parts. All of which are easily accessed when you lift the engine compartment cover, supported with two gas struts, and remove the toolless type side covers and floor plate.

Some of the photos may include optional equipment.

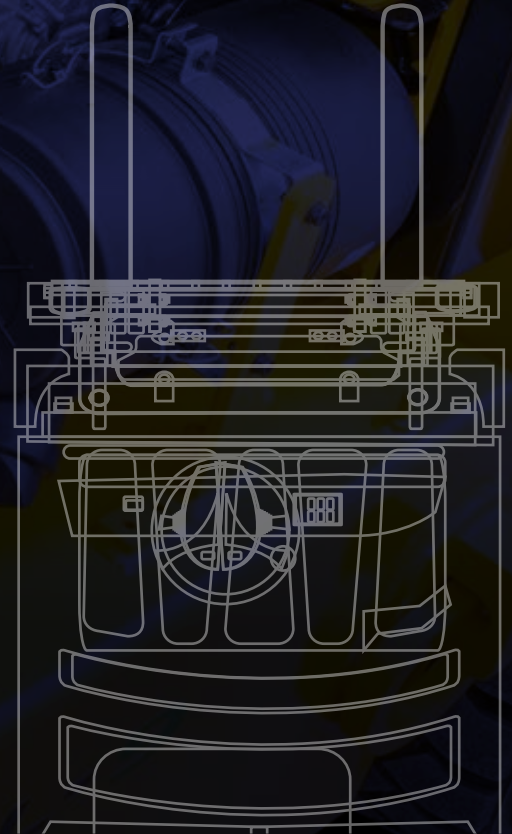



Maintenance Management

The service intervals such as engine oil, oil filter, and air filter are displayed on the cluster screen in compliance with the service intervals in the manual to deter the excessive wear and damage to functional components due to late or missed service intervals.

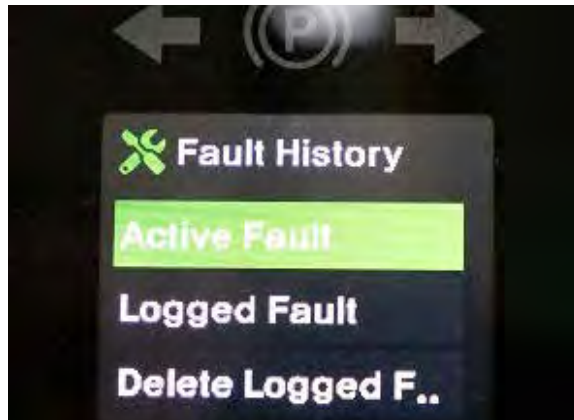

Engine Fault Diagnosis

The equipment's fault codes, which are recorded and stored by ECU and MCU, are easily accessible on the cluster screen without any additional tools to ensure rapid and precise diagnostics and repair.



IP67 Class Fuse & Relay box

The fuse and relay blocks, which are vulnerable to contamination, are contained in a water and dust tight box that is installed in the engine compartment for ease of access when maintenance is required.



Detachable Radiator Cover

The plastic toolless radiator sub hood on top of the counterweight, separated from the main hood, allows for greater access and reduces the downtime for checking the coolant level and servicing the radiator.

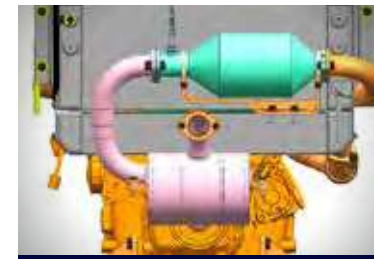

Standalone Catalyst Converter

A three-way catalyst converter added pursuant to emission regulations is installed separately from the muffler to save on the follow-up maintenance costs of the exhaust system.

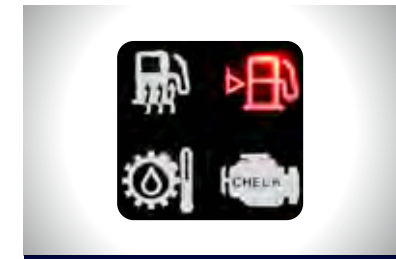

Low Fuel Warning

Monitoring of the LPG tank pressure allows the system to alert the operator of low fuel conditions via the cluster to prevent any inconvenience caused by running out of fuel during operation.



Easy Service Main Control Valve

The Main Control Valve, one of the major functional parts of the hydraulic system, is oriented to allow for easy adjustment of hydraulic pressures and spool replacement without opening the MCV assembly.

- * Integrated Flow Regulator - Easy adjustment lowering speed
- * Integrated Emergency Valve - Allows the mast to be lowered in a controlled and safe manner should an emergency situation arise.



Rear Tire and Under Cover

High quality PE material cover is installed between the steer wheels and engine compartment, as well as under the engine to reduce the intrusion of foreign substances into the engine compartment. This design extends the maintenance interval of the cooling system. (Under Cover Optional)

New 9 Series

35·40·45·50L-9

Hi-MATE, a solution for field control based on data

Continuous monitoring of the data collected from sensors and modules installed on the forklift during daily use are provided to the mobile device or computer of the customer or designated dealer in real time through Hyundai Construction Equipment's server. Such data can be used for establishing a control plan for safety in the field, productivity improvement, service intervals, and cost savings. Allowing your business to operate smarter and achieve your goals.



Equipment operation management

* Real-time monitoring and follow-up management of individual vehicles, drivers, equipment on-site, and operation information

- Key-on time, travel hours, work hours, and traveling position



Equipment status management

* Supplying vital self-diagnostics information about forklift linked with operation hours, helping to establish a service management plan

- Indicating fuel remainder, failure information
- Indicating consumable exchange timing and service intervals



Safe traveling control

* Provides alerts allowing for accountability and follow-up management of safety incidents caused by collisions involving the forklift during operation

- Records number and severity of impacts



Human resource management

* Checking and follow-up management such as matching between self-diagnostics and equipment conditions before operation

- Driver authorization, self-diagnostics of equipment conditions

Data Flow

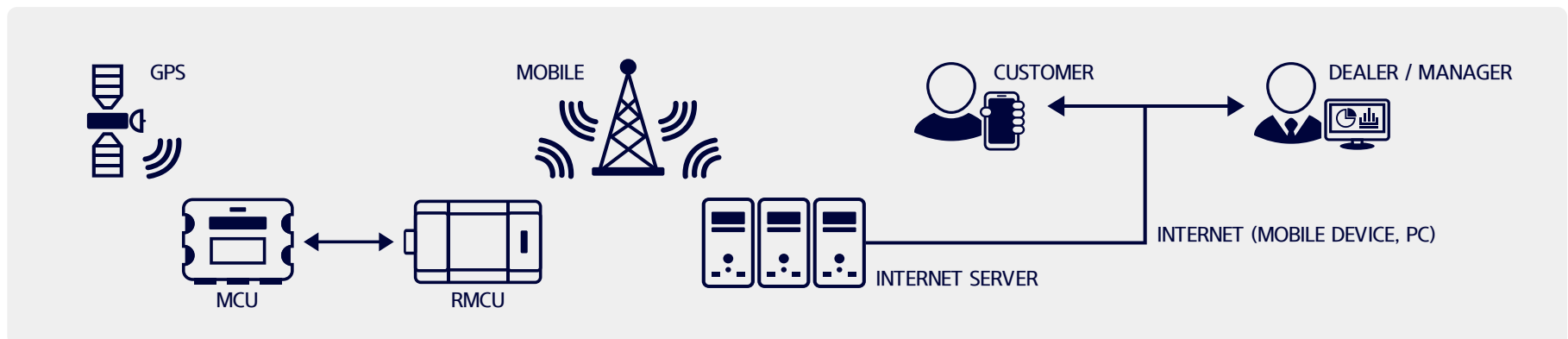

Load Capacity



35L-9

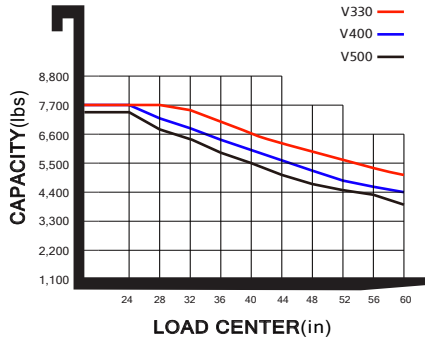

40L-9

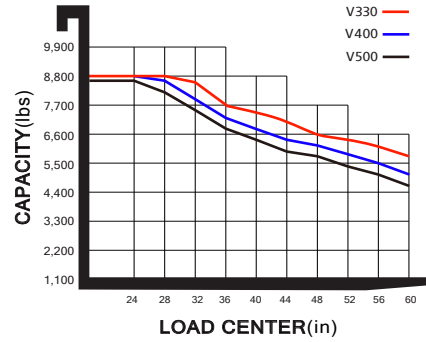

45L-9

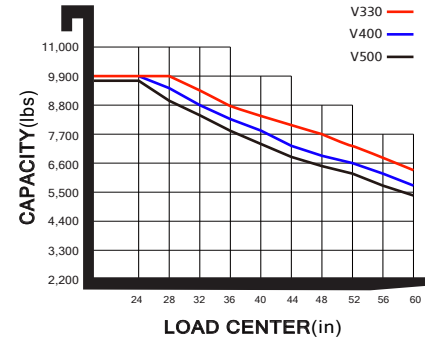

50L-9

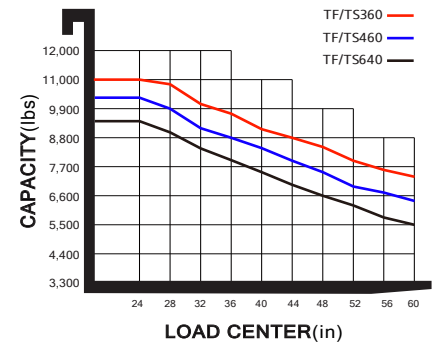
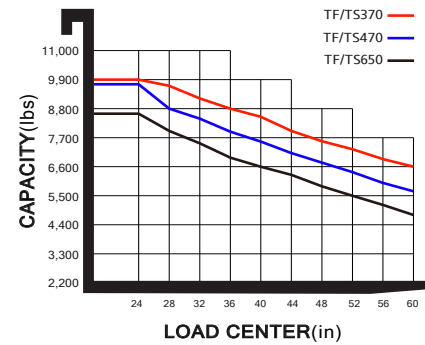
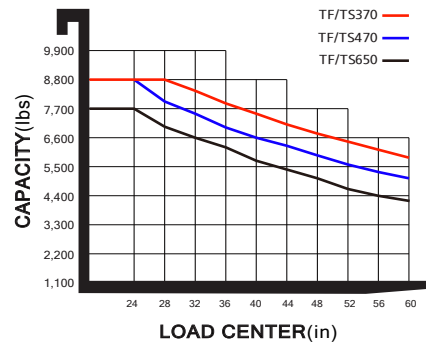
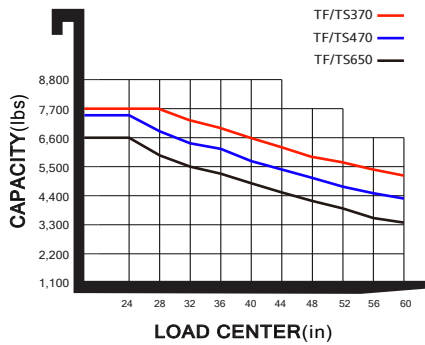
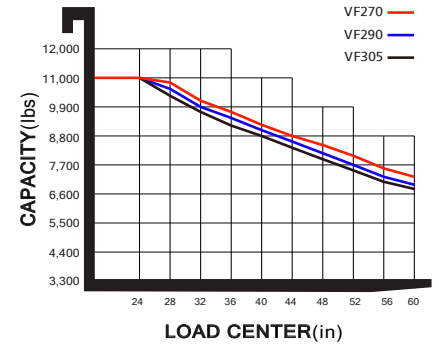
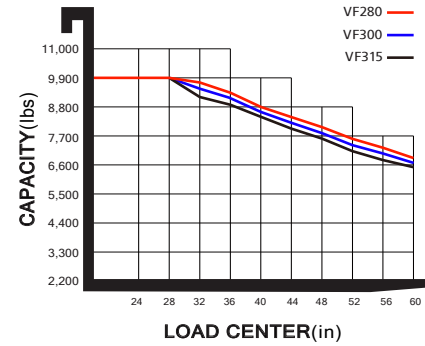
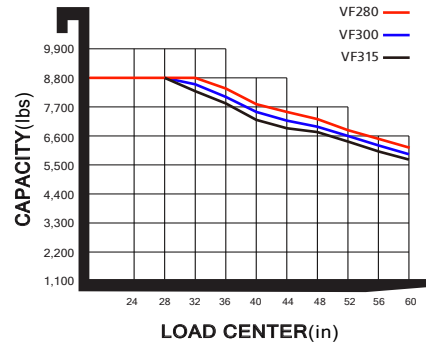
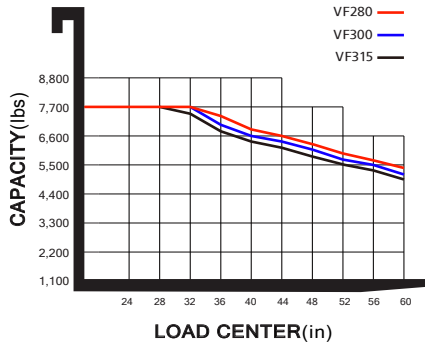
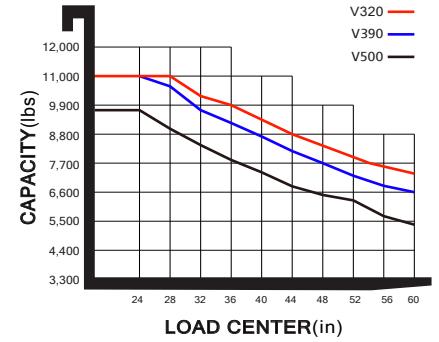

New 9 Series

35·40·45·50L-9

Standard & Optional Equipment



	Part	Description	35L-9	40L-9	45L-9	50L-9	
OPERATION AREA	OHG	Overhead Guard *35L-9 : 87.4in, 40/45/50L-9 : 87in	●	●	●	●	
		High Overhead Guard *35L-9 : 92.5in, 40/45/50L-9 : 92in	○	○	○	○	
		Overhead Guard & Rain cover *35L-9 : 87.8in, 40/45/50L-9 : 87.4in	○	○	○	○	
		High Overhead Guard & Rain cover *35L-9 : 92.9in, 40/45/50L-9 : 92.5in	○	○	○	○	
	Cabin	Cabin Options - One door, Two door	○	○	○	○	
		Cabin accessories - Front glass with Wiper, Rear glass & Top Rain Cover	○	○	○	○	
	A/C	Air Conditioner and/or Heater	○	○	○	○	
	Seat	Full Suspension Synthetic Leather Seat + Orange Belt, Arm Rest, Seat Switch	●	●	●	●	
		Seat Options - Non Suspension Seat	○	○	○	○	
	Lever	Seat accessories - HighBack Rest, Seat Switch, Seat Belt Switch, Heat	○	○	○	○	
		Lever - General	●	●	●	●	
	Other	Radio & USB	○	○	○	○	
		Rear Horn	●	●	●	●	
		Extinguisher	○	○	○	○	
MAST & ATTACHMENT	Mast	3 Stage mast - 185in Single full free(TF)	●	●	●	●	
		2 Stage mast - Standard(V), Single full free(VF)	○	○	○	○	
		3 Stage mast - Single full free(TF), Dual full free(TS)	○	○	○	○	
	Fork	48in Fork (47.2in for 50L-9)	●	●	●	●	
		Fork Options - 42in~90.5in	○	○	○	○	
	Carriage	Carriage - Narrow(51.2in/Hook)	●	●	●	●	
		Carriage Options	-	-	-	-	
		- Wide(63in/Hook)	○	○	○	○	
	Attachment	- Special(57.5in/Shaft)	○	○	○	○	
		Side Shift (Shaft - Integral type)	○	○	○	○	
		Side Shift (Hook type) - Hyundai, Cascade	○	○	○	○	
		Fork Positioner - Independent, Synchronized	○	○	○	○	
			Cascade Fork Side Shift & Positioner - Independent (Hook type)	○	○	○	○

HYDRAULICS	MCV & Hoses	4 Spool MCV + attached piping for TF470 mast	●	●	●	●
		MCV Options - 3 Spool	○	○	○	○
		MCV Options - 5 Spool	○	○	○	○
		Attached Piping for All MCVs & Masts	○	○	○	○
TIRE	Tires	Solid tires	●	●	●	●
		Tire Options	-	-	-	-
		- Pneumatic	○	○	○	○
		- Non Marking	○	○	○	○
		- Front Pneumatic + Rear Solid	○	○	○	○
		- Front Solid + Rear Pneumatic	○	○	○	○
		- Pneumatic Double(15" wheel rim)	○	○	○	○
- Solid Double(15" wheel rim)	○	○	○	○		
VISIBILITY	Lamp	Working Lamp - Front LED	●	●	●	●
		Working Lamp Options - Front LED, Rear LED, Front Bulb, Rear Bulb	○	○	○	○
		Rear Blue Spot	○	○	○	○
		LED Beacon Lamp	○	○	○	○
	Mirror	Mirror - L/H & R/H Back Mirror & Panorama Mirror	●	●	●	●
		Mirror Options - Panorama Mirror only, Outside Mirror & Panorama Mirror	○	○	○	○
	Camera	Rear Camera only	○	○	○	○
CONVE-NIENCE	-	Knob-Switch with Direction & Horn	○	○	○	○
		Auto Tilt	○	○	○	○
		Load Sensor	●	●	●	●
SAFETY	-	OPSS - Travel & Mast	●	●	●	●
		Master Switch to cut off electricity from battery	●	●	●	●
		Hazard Switch	○	○	○	○
OTHERS	-	Plastic Side Cover	●	●	●	●
		Under Cover	○	○	○	○
		Oil-VG46	●	●	●	●
		Oil Options - VG68 for Tropical, VG15 & VG32 for Cold Area	○	○	○	○
		Accumulator	○	○	○	○

● : STD / ○ : OPT

Specifications



Identification		Hyundai				
1.1	Manufacturer	Hyundai				
1.2	Manufacturer's type designation	35L-9	40L-9	45L-9	50L-9	
1.3	Drive: electric (battery or mains),diesel,petrol,fuel gas>manual	LP	LP	LP	LP	
1.4	Type of operation:hand,pedestrian,standing,seated,order-picker	Seated	Seated	Seated	Seated	
1.5	Load capacity / Rated load	lbs	8,000	9,000	10,000	11,000
1.6	Load center distance	c in	24	24	24	24
1.8	Load distance, center of drive axle to fork	x in	22	22	22	22.6
1.9	Wheelbase	y in	78.7	78.7	82.6	82.6

Weights						
2.1	Service weight	lbs	12,789	13,995	14,746	15,560
2.2	Axle loading, loaded front/rear	lbs	17,978/2,526	19,978/2,835	21,817/2,851	23,585/2,998
2.3	Axle loading, unloaded front/rear	lbs	5,787/7,002	6,045/7,950	6,418/8,332	6,389/9,172

Wheels, Chassis						
3.1	Tires:solid rubber, superelastic, pneumatic, polyurethane	Pneumatic	Pneumatic	Pneumatic	Pneumatic	
3.2	Tires size, front(ϕ x width)	8.25-15-14PR	7.50-16-12PR	7.50-16-12PR	7.50-16-12PR	
3.3	Tires size, rear(ϕ x width)	7.00-12-14PR	7.00-12-14PR	7.00-12-14PR	7.00-12-14PR	
3.5	Wheels, number front x rear (x=driven wheels)	2x2	4x2	4x2	4x2	
3.6	Track width, front	b10 (in)	44.6	50.5	50.5	50.5
3.7	Track width, rear	b11 (in)	44.9	44.9	44.9	44.9

Basic Dimensions						
4.1	Mast/fork carriage tilt forward/backward	degrees	8/10	8/10	8/10	8/10
4.2	Lowered mast height	h1 (in)	88	86.6	86.6	86.6
4.3	Free lift	h2 (in)	4.73	4.73	4.73	4.73
4.4	Lift height	h3 (in)	118.9	118.9	118.9	115.4
4.5	Extended mast height	h4 (in)	116.7	116.7	116.7	163.3
4.7	Overhead load guard (Opt.) height	h6 (in)	87(92)	87(92)	87(92)	87(92)
4.8	Seat height/ standing height	h7 (in)	42	42	42	42
4.12	Coupling height	h10 (in)	14.7	14.7	14.3	14.2
4.19	Overall length	l1 (in)	164.6	166.7	175.4	177.2
4.20	Length to face of forks	l2 (in)	122.5	124.6	129.3	131.8
4.21	Overall width	b1 (in)	54	68.5	68.5	68.5
4.22	Fork dimensions(hook type)	s/e/(mm)	1.97x4.8x42	1.97x5.9x42	1.97x5.9x48	2.36x5.9x47
4.23	Fork carriage ISO 2328, class/type A,B	III/A	III/A	IV/A	IV/A	IV/A
4.24	Fork-carriage width	b2 (in)	51	63	63	63
4.31	Ground clearance, loaded, under mast	m1(in)	6.7	6.1	6.1	6.1
4.32	Ground clearance, center of wheelbase	m2(in)	8.5	8	8	7.9
4.34.1	Aisle width for pallets 1000x1200 crossways	Ast(in)	182.2	184.1	187.8	190
4.34.2	Aisle width for pallets 800x1200 lengthways	Ast(in)	190	192	195.7	197.9
4.35	Turning radius	Wa(in)	112.9	114.8	118.5	120.2
4.36	Smallest pivot point distance	b13(in)	39.7	39.7	1,054	1,054

Performance Data						
5.1	Travel speed, unloaded	mph	19.1	18.6	18.5	18.4
5.2	Lift speed, loaded/ unloaded	fps	1.67/1.74	1.67/1.74	1.67/1.74	1.44/1.51

* All technical data & Charts on brochure are based on MAST V300 (35/40/45L-9) / V290(50L-9), Hook type Carriage, No Side shift or Fork positioner, Fork 42in (35/40L-9) / 48in (45L-9) / 47in (50L-9)mm

5.3	Lowering speed, loaded/unloaded	mm/s	1.81/1.81	1.81/1.81	1.81/1.81	1.81/1.64
5.5	Drawbar pull, loaded	lbs	-	-	-	-
5.6	Max. drawbar pull, laden/unladen	lbs	8512	8492	8516	8529
5.7	Gradient performance, loaded	%	-	-	-	-
5.8	Max. gradeability, laden/unladen	%	40.2	35.5	32.6	30.1
5.1	Service brake		Hydraulic	Hydraulic	Hydraulic	Hydraulic

Engine						
7.1	Engine manufacturer / type	KUBOTA/WG3800	KUBOTA/WG3800	KUBOTA/WG3800	KUBOTA/WG3800	
7.2	Engine power acc. to ISO 1585	hp	85	85	85	85
7.3	Rated speed	rpm	2,450	2,450	2,450	2,450
7.4	No. of cylinder / cubic capacity	anz/cm ³	4/3769	4/3769	4/3769	4/3769
7.5	Fuel consumption acc. To VDI cycle	gal/h	2.45	2.64	2.82	3.01

Other Details						
8.1	Type of drive control	Power shift 2/1	Power shift 2/1	Power shift 2/1	Power shift 2/1	
8.2	Operating pressure for attachments(System)	bar	140(190)	140(190)	140(190)	140(190)
8.3	Oil volume for attachments	l/min	60	60	60	60
8.4	Sound level at driver's ear according to DIN 12 053	dB(A)	99.1	99.1	99.1	99.1

Dimensions

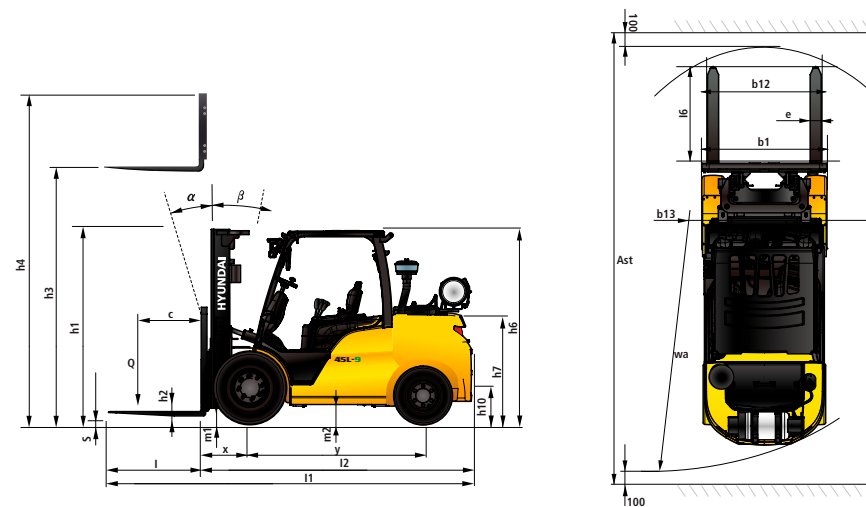

New 9 Series Mast Specifications

35L-9



Mast Type		Maximum Fork Height		Overall Height (Lowered)				Free Lift Height				Tilt Angle		Load Capacity without side shift				Load Capacity with side shift				TRUCK WEIGHT (UNLOADED)			
														Single Tire		Double Tire		Single Tire		Double Tire					
				in	mm	in	mm	in	mm	in	mm	in	mm	deg	deg	24 in LC	600mm LC	24 in LC	600mm LC	24 in LC	600mm LC	24 in LC	600mm LC	lb	kg
2-STAGE LIMITED FREE LIFT	V300	107.1	2,720	82.1	2,085	81.5	2,070	4.7	120	4.7	120	8	10	8,000	3,500	8,000	3,500	8,000	3,500	8,000	3,500	12,760	5,788	13,100	5,942
	*V300	118.9	3,020	88.0	2,235	87.4	2,220	4.7	120	4.7	120	8	10	8,000	3,500	8,000	3,500	8,000	3,500	8,000	3,500	12,826	5,818	13,167	5,972
	V330	130.7	3,320	93.9	2,385	93.3	2,370	4.7	120	4.7	120	8	10	8,000	3,500	8,000	3,500	8,000	3,500	8,000	3,500	12,909	5,856	13,250	6,010
	V350	138.6	3,520	99.8	2,535	99.2	2,520	4.7	120	4.7	120	8	10	8,000	3,500	8,000	3,500	8,000	3,500	8,000	3,500	12,960	5,879	13,301	6,033
	V370	146.5	3,720	103.7	2,635	103.1	2,620	4.7	120	4.7	120	8	10	8,000	3,500	8,000	3,500	8,000	3,500	8,000	3,500	13,004	5,899	13,345	6,053
	V400	158.3	4,020	112.0	2,845	111.4	2,830	4.7	120	4.7	120	8	10	8,000	3,500	8,000	3,500	7,480	3,400	7,590	3,450	13,098	5,941	13,439	6,096
	V430	170.1	4,320	117.9	2,995	117.3	2,980	4.7	120	4.7	120	8	10	8,000	3,500	8,000	3,500	7,370	3,350	7,480	3,400	13,223	5,998	13,563	6,152
	V450	178.0	4,520	121.9	3,095	121.3	3,080	4.7	120	4.7	120	8	6	8,000	3,500	8,000	3,500	7,260	3,300	7,370	3,350	13,347	6,054	13,687	6,208
	V500	197.6	5,020	131.7	3,345	131.1	3,330	4.7	120	4.7	120	8	6	7,480	3,400	8,000	3,500	7,040	3,200	7,150	3,250	13,459	6,105	13,799	6,259
2-STAGE FULL FREE LIFT	VF280	110.4	2,805	84.1	2,135	83.5	2,120	36.7	931	49.5	1,258	8	8	8,000	3,500	8,000	3,500	8,000	3,500	8,000	3,500	12,851	5,829	13,185	5,981
	VF300	118.3	3,005	88.0	2,235	87.4	2,220	40.6	1,031	53.5	1,358	8	8	8,000	3,500	8,000	3,500	8,000	3,500	8,000	3,500	12,908	5,855	13,242	6,007
	VF315	124.2	3,155	91.5	2,325	90.9	2,310	44.1	1,121	57.0	1,448	8	8	8,000	3,500	8,000	3,500	8,000	3,500	8,000	3,500	12,951	5,874	13,285	6,026
3-STAGE FULL FREE LIFT	TF/TS370	146.9	3,730	80.1	2,035	79.5	2,020	32.4	822	45.2	1,149	8	8	8,000	3,500	8,000	3,500	7,370	3,350	7,590	3,450	13,326	6,045	13,667	6,199
	TF/TS400	158.7	4,030	84.1	2,135	83.5	2,120	36.3	922	49.2	1,249	8	8	8,000	3,500	8,000	3,500	7,260	3,300	7,480	3,400	13,392	6,075	13,733	6,229
	TF/TS430	170.5	4,330	88.0	2,235	87.4	2,220	40.2	1,022	53.1	1,349	8	8	8,000	3,500	8,000	3,500	7,150	3,250	7,370	3,350	13,461	6,106	13,801	6,260
	TF/TS450	177.6	4,510	90.4	2,295	89.8	2,280	42.6	1,082	55.5	1,409	8	8	8,000	3,500	8,000	3,500	7,040	3,200	7,260	3,300	13,502	6,125	13,843	6,279
	TF/TS470	185.8	4,720	93.9	2,385	93.3	2,370	46.1	1,172	59.0	1,499	8	8	7,480	3,400	8,000	3,500	6,930	3,150	7,150	3,250	13,583	6,161	13,923	6,315
	TF/TS500	197.6	5,020	97.8	2,485	97.2	2,470	50.1	1,272	63.0	1,599	8	6	7,260	3,300	7,480	3,400	6,820	3,100	7,040	3,200	13,634	6,184	13,974	6,338
	TF/TS550	217.3	5,520	104.9	2,665	104.3	2,650	57.2	1,452	70.0	1,779	8	6	7,040	3,200	7,260	3,300	6,270	2,850	6,820	3,100	13,768	6,245	14,109	6,400
	TF/TS600	237.4	6,030	112.0	2,845	111.4	2,830	64.3	1,632	77.1	1,959	8	6	6,820	3,100	7,040	3,200	5,390	2,450	6,600	3,000	13,919	6,314	14,259	6,468
	TF/TS650	257.5	6,540	119.1	3,025	118.5	3,010	71.3	1,812	84.2	2,139	8	6	6,600	3,000	6,600	3,000	5,170	2,350	6,380	2,900	14,011	6,355	14,351	6,510

※ = Standard

40L-9



Mast Type		Maximum Fork Height		Overall Height (Lowered)				Free Lift Height				Tilt Angle		Load Capacity without side shift				Load Capacity with side shift				TRUCK WEIGHT (UNLOADED)			
														Single Tire		Double Tire		Single Tire		Double Tire					
				in	mm	in	mm	in	mm	in	mm	in	mm	deg	deg	24 in LC	600mm LC	24 in LC	600mm LC	24 in LC	600mm LC	24 in LC	600mm LC	lb	kg
		in	mm	in	mm	in	mm	in	mm	in	mm	deg	deg	lb	kg	lb	kg	lb	kg	lb	kg	lb	kg	lb	kg
2-STAGE LIMITED FREE LIFT	V270	107.1	2,720	82.1	2,085	81.5	2,070	4.7	120	4.7	120	8	10	9,000	4,000	9,000	4,000	9,000	4,000	9,000	4,000	13,711	6,219	13,977	6,340
	※V300	118.9	3,020	88.0	2,235	87.4	2,220	4.7	120	4.7	120	8	10	9,000	4,000	9,000	4,000	9,000	4,000	9,000	4,000	13,778	6,249	14,043	6,370
	V330	130.7	3,320	93.9	2,385	93.3	2,370	4.7	120	4.7	120	8	10	9,000	4,000	9,000	4,000	9,000	4,000	9,000	4,000	13,861	6,287	14,126	6,408
	V350	138.6	3,520	99.8	2,535	99.2	2,520	4.7	120	4.7	120	8	10	9,000	4,000	9,000	4,000	9,000	4,000	9,000	4,000	13,912	6,310	14,177	6,431
	V370	146.5	3,720	103.7	2,635	103.1	2,620	4.7	120	4.7	120	8	10	9,000	4,000	9,000	4,000	8,888	3,950	8,888	3,950	13,956	6,330	14,222	6,451
	V400	158.3	4,020	112.0	2,845	111.4	2,830	4.7	120	4.7	120	8	10	9,000	4,000	9,000	4,000	8,775	3,900	8,775	3,900	14,050	6,373	14,315	6,493
	V430	170.1	4,320	117.9	2,995	117.3	2,980	4.7	120	4.7	120	8	10	9,000	4,000	9,000	4,000	8,663	3,850	8,663	3,850	14,174	6,429	14,440	6,550
	V450	178.0	4,520	121.9	3,095	121.3	3,080	4.7	120	4.7	120	8	6	9,000	4,000	9,000	4,000	8,550	3,800	8,550	3,800	14,298	6,486	14,564	6,606
V500	197.6	5,020	131.7	3,345	131.1	3,330	4.7	120	4.7	120	8	6	8,775	3,900	9,000	4,000	8,325	3,700	8,325	3,700	14,410	6,536	14,676	6,657	
2-STAGE FULL FREE LIFT	VF280	110.4	2,805	84.1	2,135	83.5	2,120	36.1	916	48.9	1,243	8	8	9,000	4,000	9,000	4,000	9,000	4,000	9,000	4,000	13,724	6,225	14,060	6,377
	VF300	118.3	3,005	88.0	2,235	87.4	2,220	40.0	1,016	52.9	1,343	8	8	9,000	4,000	9,000	4,000	9,000	4,000	9,000	4,000	13,782	6,251	14,117	6,404
	VF315	124.2	3,155	91.5	2,325	90.9	2,310	43.5	1,106	56.4	1,433	8	8	9,000	4,000	9,000	4,000	9,000	4,000	9,000	4,000	13,824	6,271	14,160	6,423
3-STAGE FULL FREE LIFT	TF/TS370	146.9	3,730	80.1	2,035	79.5	2,020	31.8	807	44.6	1,134	8	8	9,000	4,000	9,000	4,000	8,775	3,900	8,888	3,950	14,278	6,476	14,543	6,597
	TF/TS400	158.7	4,030	84.1	2,135	83.5	2,120	35.7	907	48.6	1,234	8	8	9,000	4,000	9,000	4,000	8,663	3,850	8,663	3,850	14,343	6,506	14,609	6,627
	TF/TS430	170.5	4,330	88.0	2,235	87.4	2,220	39.6	1,007	52.5	1,334	8	8	9,000	4,000	9,000	4,000	8,550	3,800	8,550	3,800	14,412	6,537	14,678	6,658
	TF/TS450	177.6	4,510	90.4	2,295	89.8	2,280	42.0	1,067	54.9	1,394	8	8	9,000	4,000	9,000	4,000	8,550	3,800	8,550	3,800	14,454	6,556	14,719	6,677
	TF/TS470	185.8	4,720	93.9	2,385	93.3	2,370	45.6	1,157	58.4	1,484	8	8	9,000	4,000	9,000	4,000	8,325	3,700	8,438	3,750	14,534	6,593	14,800	6,713
	TF/TS500	197.6	5,020	97.8	2,485	97.2	2,470	49.5	1,257	62.4	1,584	8	6	8,775	3,900	8,775	3,900	8,100	3,600	8,213	3,650	14,585	6,616	14,851	6,736
	TF/TS550	217.3	5,520	104.9	2,665	104.3	2,650	56.6	1,437	69.4	1,764	8	6	8,325	3,700	8,550	3,800	7,370	3,350	7,700	3,500	14,720	6,677	14,985	6,797
	TF/TS600	237.4	6,030	112.0	2,845	111.4	2,830	63.7	1,617	76.5	1,944	8	6	7,920	3,600	7,920	3,600	6,490	2,950	7,480	3,400	14,870	6,745	15,136	6,866
TF/TS650	257.5	6,540	119.1	3,025	118.5	3,010	70.7	1,797	83.6	2,124	8	6	7,700	3,500	7,700	3,500	6,270	2,850	7,260	3,300	14,962	6,787	15,228	6,907	

※ = Standard

New 9 Series Mast Specifications

45L-9



Mast Type		Maximum Fork Height		Overall Height (Lowered)				Free Lift Height				Tilt Angle		Load Capacity without side shift				Load Capacity with side shift				TRUCK WEIGHT (UNLOADED)			
														Single Tire		Double Tire		Single Tire		Double Tire					
				in	mm	in	mm	in	mm	in	mm	in	mm	deg	deg	24 in LC	600mm LC	24 in LC	600mm LC	24 in LC	600mm LC	24 in LC	600mm LC	lb	kg
2-STAGE LIMITED FREE LIFT	V270	107.1	2,720	82.1	2,085	81.5	2,070	4.7	120	4.7	120	8	10	10,000	4,500	10,000	4,500	10,000	4,500	10,000	4,500	14,459	6,559	14,738	6,685
	※V300	118.9	3,020	88.0	2,235	87.4	2,220	4.7	120	4.7	120	8	10	10,000	4,500	10,000	4,500	10,000	4,500	10,000	4,500	14,526	6,589	14,805	6,715
	V330	130.7	3,320	93.9	2,385	93.3	2,370	4.7	120	4.7	120	8	10	10,000	4,500	10,000	4,500	10,000	4,500	10,000	4,500	14,609	6,626	14,888	6,753
	V350	138.6	3,520	99.8	2,535	99.2	2,520	4.7	120	4.7	120	8	10	10,000	4,500	10,000	4,500	10,000	4,500	10,000	4,500	14,660	6,650	14,939	6,776
	V370	146.5	3,720	103.7	2,635	103.1	2,620	4.7	120	4.7	120	8	10	10,000	4,500	10,000	4,500	9,680	4,400	9,680	4,400	14,704	6,670	14,983	6,796
	V400	158.3	4,020	112.0	2,845	111.4	2,830	4.7	120	4.7	120	8	10	10,000	4,500	10,000	4,500	9,570	4,350	9,570	4,350	14,798	6,712	15,077	6,839
	V430	170.1	4,320	115.9	2,945	117.3	2,980	4.7	120	4.7	120	8	10	10,000	4,500	10,000	4,500	9,460	4,300	9,460	4,300	14,922	6,769	15,201	6,895
	V450	178.0	4,520	121.9	3,095	121.3	3,080	4.7	120	4.7	120	8	6	10,000	4,500	10,000	4,500	9,240	4,200	9,240	4,200	15,046	6,825	15,325	6,951
	V500	197.6	5,020	131.7	3,345	131.1	3,330	4.7	120	4.7	120	8	6	9,680	4,400	9,680	4,400	8,910	4,050	8,910	4,050	15,158	6,876	15,437	7,002
2-STAGE FULL FREE LIFT	VF280	110.4	2,805	84.1	2,135	83.5	2,120	33.6	853	56.8	1,442	8	8	10,000	4,500	10,000	4,500	10,000	4,500	10,000	4,500	14,539	6,595	14,818	6,721
	VF300	118.3	3,005	88.0	2,235	87.4	2,220	37.5	953	60.7	1,542	8	8	10,000	4,500	10,000	4,500	10,000	4,500	10,000	4,500	14,596	6,621	14,875	6,747
	VF315	124.2	3,155	91.5	2,325	90.9	2,310	41.1	1,043	63.1	1,602	8	8	10,000	4,500	10,000	4,500	10,000	4,500	10,000	4,500	14,639	6,640	14,918	6,767
3-STAGE FULL FREE LIFT	TF/TS370	146.9	3,730	80.1	2,035	79.5	2,020	31.3	796	43.9	1,114	8	8	10,000	4,500	10,000	4,500	9,570	4,350	9,570	4,350	15,026	6,816	15,310	6,945
	TF/TS400	158.7	4,030	84.1	2,135	83.5	2,120	35.3	896	47.8	1,214	8	8	10,000	4,500	10,000	4,500	9,460	4,300	9,460	4,300	15,092	6,846	15,376	6,975
	TF/TS430	170.5	4,330	88.0	2,235	87.4	2,220	39.2	996	51.7	1,314	8	8	10,000	4,500	10,000	4,500	9,240	4,200	9,240	4,200	15,161	6,877	15,445	7,006
	TF/TS450	177.6	4,510	90.4	2,295	89.8	2,280	41.6	1,056	54.1	1,374	8	8	10,000	4,500	10,000	4,500	9,130	4,150	9,130	4,150	15,202	6,896	15,486	7,025
	TF/TS470	185.8	4,720	93.9	2,385	93.3	2,370	45.1	1,145	58.4	1,484	8	8	9,680	4,400	9,680	4,400	9,020	4,100	9,020	4,100	15,283	6,932	15,567	7,061
	TF/TS500	197.6	5,020	97.8	2,485	97.2	2,470	49.1	1,246	61.6	1,564	8	6	9,460	4,300	9,460	4,300	8,800	4,000	8,800	4,000	15,333	6,955	15,618	7,084
	TF/TS550	217.3	5,520	104.9	2,665	104.3	2,650	56.1	1,426	68.7	1,744	8	6	9,240	4,200	9,240	4,200	8,470	3,850	8,470	3,850	15,468	7,016	15,753	7,145
	TF/TS600	237.4	6,030	112.0	2,845	111.4	2,830	63.2	1,606	75.7	1,924	8	6	8,800	4,000	8,800	4,000	7,150	3,250	8,250	3,750	15,619	7,085	15,903	7,214
	TF/TS650	257.5	6,540	119.1	3,025	118.5	3,010	70.3	1,786	82.8	2,104	8	6	8,580	3,900	8,580	3,900	6,930	3,150	8,030	3,650	15,711	7,126	15,995	7,255

※ = Standard

50L-9



Mast Type		Maximum Fork Height		Overall Height (Lowered)				Free Lift Height				Tilt Angle		Load Capacity without side shift				Load Capacity with side shift				TRUCK WEIGHT (UNLOADED)					
														Single Tire		Double Tire		Single Tire		Double Tire							
		in	mm	in	mm	in	mm	in	mm	in	mm	deg	deg	24 in LC	600mm LC	24 in LC	600mm LC	24 in LC	600mm LC	24 in LC	600mm LC	lb	kg	lb	kg	lb	kg
2-STAGE LIMITED FREE LIFT	V260	103.5	2,630	82.1	2,085	81.5	2,070	4.7	120	4.7	120	8	10	11,000	5,000	11,000	5,000	11,000	5,000	11,000	5,000	15,326	6,952	15,521	7,040		
	※V290	115.4	2,930	88.0	2,235	87.4	2,220	4.7	120	4.7	120	8	10	11,000	5,000	11,000	5,000	11,000	5,000	11,000	5,000	15,494	7,028	15,689	7,116		
	V320	127.2	3,230	93.9	2,385	93.3	2,370	4.7	120	4.7	120	8	10	11,000	5,000	11,000	5,000	11,000	5,000	11,000	5,000	15,437	7,002	15,632	7,091		
	V340	135.0	3,430	99.8	2,535	99.2	2,520	4.7	120	4.7	120	8	10	11,000	5,000	11,000	5,000	10,890	4,950	10,890	4,950	15,491	7,027	15,687	7,115		
	V360	142.9	3,630	103.7	2,635	103.1	2,620	4.7	120	4.7	120	8	10	11,000	5,000	11,000	5,000	10,780	4,900	10,780	4,900	15,528	7,043	15,723	7,132		
	V390	154.7	3,930	112.0	2,845	111.4	2,830	4.7	120	4.7	120	8	10	11,000	5,000	11,000	5,000	10,560	4,800	10,560	4,800	15,606	7,079	15,801	7,167		
	V440	174.4	4,430	121.9	3,095	121.3	3,080	4.7	120	4.7	120	8	6	10,780	4,900	11,000	5,000	10,230	4,650	10,230	4,650	15,834	7,182	16,029	7,270		
V490	194.1	4,930	131.7	3,345	131.1	3,330	4.7	120	4.7	120	8	6	10,560	4,800	10,780	4,900	9,900	4,500	9,900	4,500	15,927	7,224	16,122	7,313			
2-STAGE FULL FREE LIFT	VF270	106.4	2,702	84.1	2,135	83.5	2,120	35.6	905	48.1	1,223	8	8	11,000	5,000	11,000	5,000	10,340	4,700	11,000	5,000	15,457	7,011	15,644	7,096		
	VF290	114.3	2,902	88.0	2,235	87.4	2,220	39.6	1,005	52.1	1,323	8	8	11,000	5,000	11,000	5,000	10,230	4,650	11,000	5,000	15,512	7,036	15,699	7,121		
	VF305	120.2	3,052	91.5	2,325	90.9	2,310	43.1	1,095	55.6	1,413	8	8	11,000	5,000	11,000	5,000	10,010	4,550	11,000	5,000	15,552	7,054	15,738	7,139		
3-STAGE FULL FREE LIFT	TF/TS360	144.6	3,672	80.1	2,035	79.5	2,020	31.8	8,07	42.3	1,074	8	8	11,000	5,000	11,000	5,000	10,340	4,700	10,560	4,800	15,863	7,195	16,032	7,272		
	TF/TS390	156.4	3,972	84.1	2,135	83.5	2,120	35.7	9,07	46.2	1,174	8	8	11,000	5,000	11,000	5,000	10,230	4,650	10,340	4,700	15,921	7,222	16,089	7,298		
	TF/TS420	168.2	4,272	88.0	2,235	87.4	2,220	39.6	1,007	50.2	1,274	8	8	10,780	4,900	11,000	5,000	10,010	4,550	10,120	4,600	15,976	7,247	16,144	7,323		
	TF/TS440	175.3	4,452	90.4	2,295	89.8	2,280	42.0	1,067	52.5	1,334	8	8	10,560	4,800	11,000	5,000	9,900	4,500	10,010	4,550	16,012	7,263	16,180	7,339		
	TF/TS460	183.5	4,662	93.9	2,385	93.3	2,370	45.5	1,157	56.1	1,424	8	8	10,340	4,700	10,780	4,900	9,790	4,450	9,900	4,500	16,064	7,286	16,232	7,363		
	TF/TS490	195.4	4,962	97.8	2,485	97.2	2,470	49.5	1,257	60.0	1,524	8	6	10,120	4,600	10,560	4,800	9,570	4,350	9,790	4,450	16,119	7,312	16,288	7,388		
	TF/TS540	215.0	5,462	104.9	2,665	104.3	2,650	56.6	1,437	67.1	1,704	8	6	9,900	4,500	10,340	4,700	9,350	4,250	9,460	4,300	16,234	7,364	16,403	7,440		
	TF/TS590	235.1	5,972	112.0	2,845	111.4	2,830	63.6	1,617	74.2	1,884	8	6	9,680	4,400	10,120	4,600	9,020	4,100	9,240	4,200	16,322	7,404	16,491	7,480		
TF/TS640	255.2	6,482	119.1	3,025	118.5	3,010	70.7	1,797	81.3	2,064	8	6	9,460	4,300	9,900	4,500	8,800	4,000	9,020	4,100	16,414	7,445	16,583	7,522			

※ = Standard

Hyundai Construction Equipment Global Network

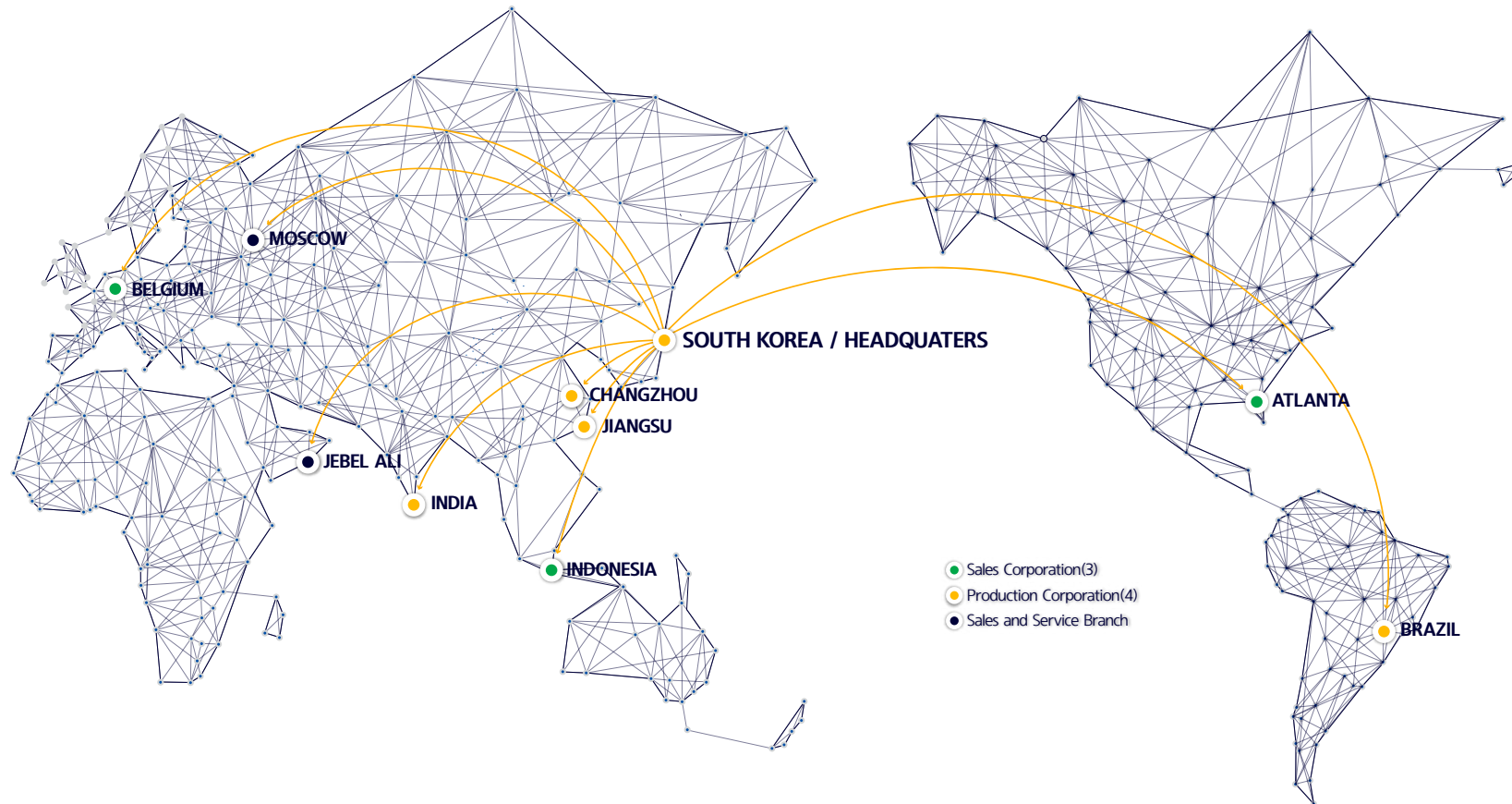

BELGIUM



ATLANTA



JIANGSU



INDIA



BRAZIL



MONTREAL (Head office)

100A, Hymus Blvd.
 Pointe-Claire (Québec) H9R 1E4
 Phone: 514 694-4223
 Toll free: 1 866 421-4223
info@elevex.ca

SAGUENAY

2305, Alexis-Le-Trotteur Street
 Jonquière (Québec) G7X 9H8
 Phone : 418 543-0000
 Toll free: 1 866 421-4223



NORTH AMERICAN HEADQUARTERS
 6100 ATLANTIC BLVD, NORCROSS, GA 30071
 TEL (678) 823 7777 FAX (687) 823 7778
www.hyundaiforkliftamericas.com Rev. 02.2022

