



MOVING YOU FURTHER

**35·40**

**45D-9F**

**50DA-9F**



Some of the photos may include optional equipment.



# Your satisfaction is our priority!

**Qualified performance! The best design!  
Hyundai 9 Series medium-size diesel forklift**

Hyundai introduces a new line of 9F-series diesel forklift trucks.

These forklifts deliver outstanding performance for every working environment and economic value.

The new Hyundai diesel forklifts bring you efficiency and comfort.



- Powerful performance
- Spacious operating space
- Grammer seat standard
- Push-type inching system  
: inching pedal, pedal force relieved
- 5.6 inch LCD color monitor
- Machine inclination warning system
- Speed limit setting
- Operator Presence Sensing System (OPSS)
- Load weight indicator
- Auto fork leveling system (OPT)



Power & Performance

# Strong power, High performance

The 9F-series forklifts are designed to achieve optimized performance in any work environment.



HIGH PERFORMANCE

POWERFUL ENGINE

Some of the photos may include optional equipment.



## Powerful and economical KUBOTA V3800 Engine!

(Complies with Tier-4 exhaust gas regulation)

No Adblue required due to adoption of device for postprocessing DOC exhaust gas

The electronic turbo KUBOTA engine guarantees optimized work efficiency under any working conditions. Fuel efficiency is enhanced and high capacity with low noise is realized by direct injection and optimized driving system. In addition, there's no need to inject Adblue due to adoption of the Diesel Oxidation Catalyst (DOC) as an exhaust gas postprocessing device. It is possible to reduce maintenance costs and maintain easily.

**75.3PS/56.1kW@2,200rpm (gross)**  
**228.5lbf-ft/31.6kgf•m@1,500rpm (gross)**

## Excellent gradeability and travel speed

Equipped with the most powerful engine in its class, the 9F-series can perform stable operations and provides excellent gradeability and fast travel speed on any tough terrain or slope.

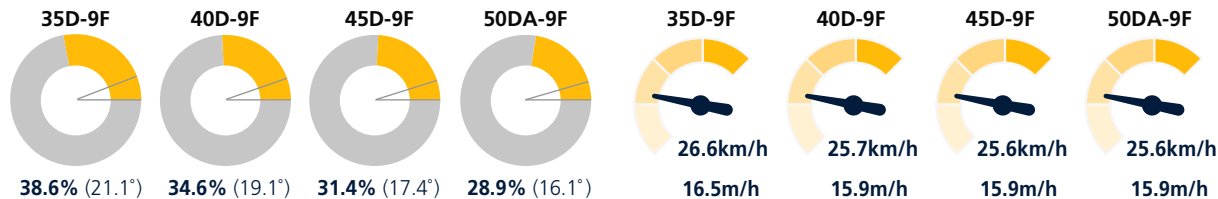

Max. Gradeability (Loaded)

Max. Travel Speed (Unloaded)



### Highly Durable Transmission

The two-speed powershift transmission provides smooth efficient operation with both automatic and manual shift modes. The clutch protection system prevents excessive use of inching as well as minimizes change-impact.



### Powerful drive axle and wet brake

A strong drive axle separate from the transmission ensures low vibration and easy maintenance. The wet disc brake system is virtually maintenance free and the enclosed design protects from dust and water.



### Hydraulic Brake Booster

Hydraulic assisted brakes provide strong, consistent brake performance.



### Fully hydraulic steering system

The hydraulic steering system guarantees simple and quick operation, preventing kick-back.



### Integrated wheel rim

The integrated wheel rim provides significantly increased service life.



Easy & Comfort

# Comfortable work space Intuitive monitoring

Ergonomic design for convenience of the operator  
Wider visibility and intuitively configured monitoring system  
We ensures your comfort in any work environment.

COMFORTABLE WORKSPACE



ADVANCED MONITORING  
SYSTEM



Some of the photos may include optional equipment.

## Ergonomically designed operating space

The ergonomically designed operating space will further enhance the operator's work efficiency. The elevated seat with back rest and a handle with a reduced diameter enlarge the frontal view while reducing the operator's fatigue. The adoption of an A4-sized tray increases the convenience of document storage, while the 12V power socket (optional) facilitates the use of small electronic products.



### Automatic gear shift

When accelerating at 5 km/h or faster, the gear shifts automatically from first to second; and when decelerating at 3 km/h or slower, it shifts from second to first. Thus enhancing the operator's convenience.



### Adjustable tilting handle

The angle of the steering column can easily be adjusted to improve driver comfort.



### Grammer seat (STD)

Easily adjustable suspension seat, based on a human engineering design, reduces operator fatigue and provides greater comfort.

- ELR (Emergency Locking Retractor) type seat belt as a standard
- Heating and head rest (OPT)



### Open footplate

A larger safety footplate with antislip provides convenience and safe access for the operator.

## 5.6-inch large screen LCD monitor

The TFT LCD color monitor with 5.6-inch large screen allow the operator to identify speed, driving direction, and operating hours at a glance and control the vehicle efficiently. Fault diagnosis is possible without any additional diagnostic apparatus due to the message delivery function.



### Speed limit setting

As the vehicle's speed limit can be set up between 8 and 20km/h at 1km/h, operator can comply with the speed limit.

### Machine inclination indication

The grade and slope sensors are built into the MCU and provide the machine's inclination in real time.

A warning alarm is triggered if the KS STD limit is exceeded.

### Load weight indicator

The precise load sensor reduces the time taken to measure a carriage load, and a warning is given at the time of overload.

### Main monitoring features

- Driving speed gauge
- Hour-meter
- Fuel gauge
- Engine temperature gauge
- Gear status indicator
- Other indicator lights / warning lights



Secure & Safety

# Excellent visibility

# Reliable safety

Interior space and strength are designed with safety as the priority, thus enable the operator to focus on work safely and conveniently.

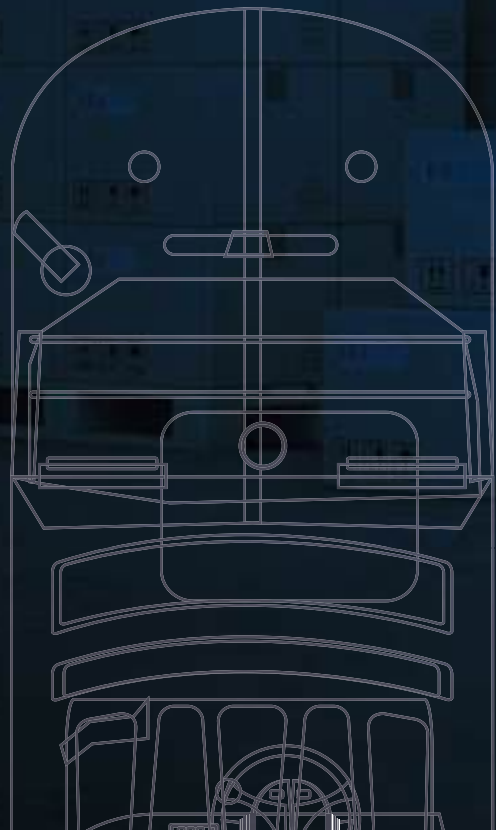

EXCELLENT VISIBILITY

ADVANCED SAFETY

Some of the photos may include optional equipment.

# Wide visibility for Safe Operation

The optimized lift cylinder array design provides a clear, wide field of vision for the operator. The adoption of a panorama mirror improves the rear side view, further enhancing safety.



Some of the photos may include optional equipment.



## High-strength overhead guard

The strong overhead guard meets the ANSI regulations and provides wide visibility by increasing the opening in the ceiling.



## Rear view camera (OPT)

The rear-view camera and monitor inter-operated with the reverse gear ensure a safer rear-side work environment.



## Panoramic mirror

The adoption of the panoramic mirror eliminates blind spots at the rear and ensures a wider rear view.

# Various Safety System

The adoption of a high-sensitivity sensor and advanced safety system eliminates the risk of safety accidents.



## Auto parking brake (OPT)

If the operator leaves the seat while the gear lever is in neutral, the parking brake is automatically engaged to secure safety, and released upon the operator's return to the seat.

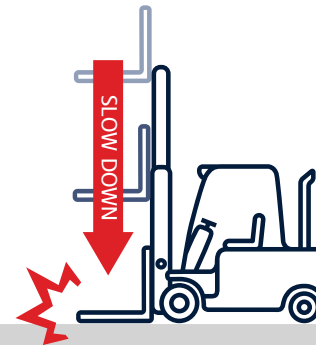

## Fork safety features

The down-safety valve prevents forks from dropping down in case of sudden damage of hydraulic line.

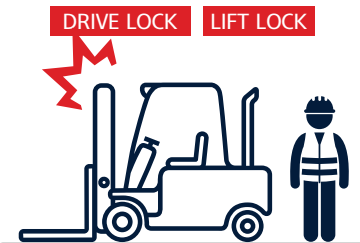

## Operator Presence Sensing System

All mast and drive movements stop functioning when the operator is not in the seat.

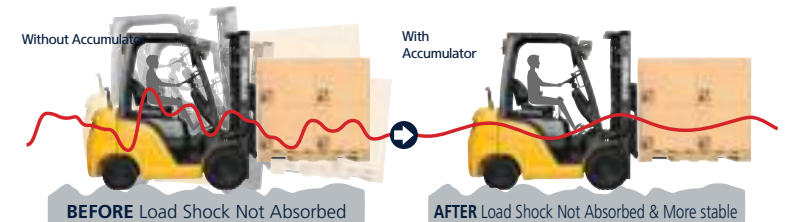

## Mast Accumulator for load cushioning (OPT)

The accumulator installed at the side of mast prevents the lift cylinder from moving up and down when driving on an uneven road surface.



Maintenance & Convenience

# Easy maintenance Various convenience devices

Ideal design for daily inspection and maintenance.  
High-quality convenience devices for operator  
Operator can work in the best conditions  
in any environment.

EASY MAINTENANCE

BEST CONVENIENCE

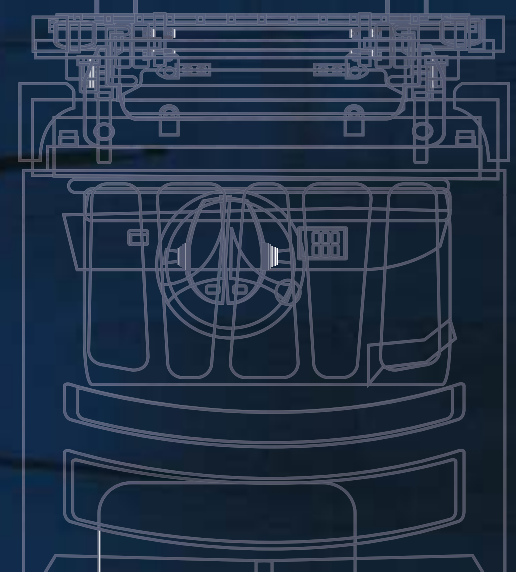

## Large Engine Hood

An ideal arrangement of components ensures easy access and convenience for maintenance. The enlarged air cleaner (8") has extended service time of engine and durability has been improved with the adoption of a bonnet gas spring (left/right).



**Waterproof & Dustproof cover**

Newly developed waterproof and dustproof fuse box and relay box for ease of maintenance.

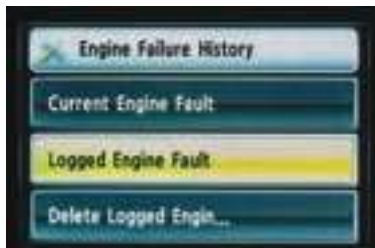

**Engine fault diagnosis**

Details of engine fault diagnosed by the engine control unit (ECU) can be checked on the dashboard.



**Maintenance management**

This indicator automatically alerts the operator of the replacement cycle of key consumable items.

## Various convenience devices

Various functions provide safety and convenience for operator.



**Emergency switch (OPT)**

A button-type switch enables to notify of emergency situations quickly.



**Password starting system**

The equipment can be managed safely and protected from theft by designating operator's right.

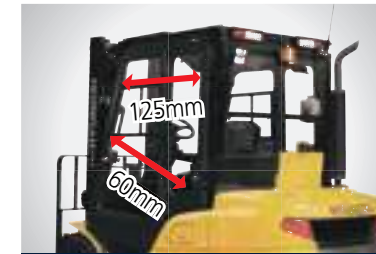

**Wide cabin (OPT)**

A wide cabin can be selected (60 mm wide and 125 mm long) for wider indoor space.



**Fuel cover with key**

Locking fuel inlet door prevents theft.



**Bolt on type cabin**

The bolt on type cabin consists of front side, door front, door rear, and rear side. It is easy to assemble by bolt and mount parts. Also, the cabin can be selected by module or parts and air conditioner and heater are separately available for driver's comfort.

# New 9 Series Mast Specifications

**35/40/45D-9F**  
**50DA-9F**

## 35D-9F



Mast Type	Maximum Fork Height		Overall Height (Lowered)				Free lift height				Tilt Angle		Load capacity w/o side shift				Load capacity w/side shift				TRUCK WEIGHT (UNLOADED)				
			Single Tire		Double Tire		With Load Backrest		Without Load Backrest		Fwd	Bwd	Single Tire		Double Tire		Single Tire		Double Tire		Single Tire		Double Tire		
			in	mm	in	mm	in	mm	in	mm			24 in LC	600mm LC	24 in LC	600mm LC	24 in LC	600mm LC	24 in LC	600mm LC	24 in LC	600mm LC	24 in LC	600mm LC	24 in LC
	in		mm		in		mm		deg		deg		lb		kg		lb		kg		lb		kg		
2-STAGE LIMITED FREE LIFT	V270	107.1	2,720	82.1	2,085	81.5	2,070	4.7	120	4.7	120	8	10	8,000	3,500	8,000	3,500	8,000	3,500	8,000	3,500	12,901	5,864	13,229	6,013
	※V300	118.9	3,020	88.0	2,235	87.4	2,220	4.7	120	4.7	120	8	10	8,000	3,500	8,000	3,500	8,000	3,500	8,000	3,500	12,967	5,894	13,295	6,043
	V330	130.7	3,320	93.9	2,385	93.3	2,370	4.7	120	4.7	120	8	10	8,000	3,500	8,000	3,500	8,000	3,500	8,000	3,500	13,050	5,932	13,378	6,081
	V350	138.6	3,520	99.8	2,535	99.2	2,520	4.7	120	4.7	120	8	10	8,000	3,500	8,000	3,500	8,000	3,500	8,000	3,500	13,101	5,955	13,429	6,104
	V370	146.5	3,720	103.7	2,635	103.1	2,620	4.7	120	4.7	120	8	10	8,000	3,500	8,000	3,500	8,000	3,500	8,000	3,500	13,145	5,975	13,473	6,124
	V400	158.3	4,020	112.0	2,845	111.4	2,830	4.7	120	4.7	120	8	10	8,000	3,500	8,000	3,500	7,480	3,400	7,590	3,450	13,237	6,017	13,565	6,166
	V430	170.1	4,320	117.9	2,995	117.3	2,980	4.7	120	4.7	120	8	10	8,000	3,500	8,000	3,500	7,370	3,350	7,480	3,400	13,303	6,047	13,631	6,196
	V450	178.0	4,520	121.9	3,095	121.3	3,080	4.7	120	4.7	120	8	6	8,000	3,500	8,000	3,500	7,260	3,300	7,370	3,350	13,486	6,130	13,814	6,279
V500	197.6	5,020	131.7	3,345	131.1	3,330	4.7	120	4.7	120	8	6	7,480	3,400	8,000	3,500	7,040	3,200	7,150	3,250	13,598	6,181	13,926	6,330	
2-STAGE FULL	VF280	110.4	2,805	84.1	2,135	83.5	2,120	36.7	93.1	49.5	1,258	8	8	8,000	3,500	8,000	3,500	8,000	3,500	8,000	3,500	13,028	5,922	13,361	6,073
FREE LIFT	VF300	118.3	3,005	88.0	2,235	87.4	2,220	40.6	1,031	53.5	1,358	8	8	8,000	3,500	8,000	3,500	8,000	3,500	8,000	3,500	13,086	5,948	13,418	6,099
	VF315	124.2	3,155	91.5	2,325	90.9	2,310	44.1	1,121	57.0	1,448	8	8	8,000	3,500	8,000	3,500	8,000	3,500	8,000	3,500	13,127	5,967	13,462	6,119
3-STAGE FULL FREE LIFT	TF/TS370	146.9	3,730	80.1	2,035	79.5	2,020	32.4	82.2	45.2	1,149	8	8	8,000	3,500	8,000	3,500	7,370	3,350	7,590	3,450	13,438	6,108	13,765	6,257
	TF/TS400	158.7	4,030	84.1	2,135	83.5	2,120	36.3	92.2	49.2	1,249	8	8	8,000	3,500	8,000	3,500	7,260	3,300	7,480	3,400	13,504	6,138	13,831	6,287
	TF/TS430	170.5	4,330	88.0	2,235	87.4	2,220	40.2	1,022	53.1	1,349	8	8	8,000	3,500	8,000	3,500	7,150	3,250	7,370	3,350	13,631	6,196	13,900	6,318
	TF/TS450	177.6	4,510	90.4	2,295	89.8	2,280	42.6	1,082	55.5	1,409	8	8	8,000	3,500	8,000	3,500	7,040	3,200	7,260	3,300	13,614	6,188	13,941	6,337
	TF/TS470	185.8	4,720	93.9	2,385	93.3	2,370	46.1	1,172	59.0	1,499	8	8	7,480	3,400	8,000	3,500	6,930	3,150	7,150	3,250	13,693	6,224	14,021	6,373
	TF/TS500	197.6	5,020	97.8	2,485	97.2	2,470	50.1	1,272	63.0	1,599	8	6	7,260	3,300	7,480	3,400	6,820	3,100	7,040	3,200	13,743	6,247	14,071	6,396
	TF/TS550	217.3	5,520	104.9	2,665	104.3	2,650	57.2	1,452	70.0	1,779	8	6	7,040	3,200	7,260	3,300	6,270	2,850	6,820	3,100	13,880	6,309	14,208	6,458
	TF/TS600	237.4	6,030	112.0	2,845	111.4	2,830	64.3	1,632	77.1	1,959	8	6	6,820	3,100	7,040	3,200	5,390	2,450	6,600	3,000	13,963	6,347	14,351	6,523
TF/TS650	257.5	6,540	119.1	3,025	118.5	3,010	71.3	1,812	84.2	2,139	8	6	6,600	3,000	6,600	3,000	5,170	2,350	6,380	2,900	14,214	6,461	14,542	6,610	

※ TF-Mast : Wide Visible 3-Stage Full Free Lift Mast with 1 Free Lift Cylinder  
 ※ TS-Mast : Wide Visible 3-Stage Full Free Lift Mast with 2 Free Lift Cylinders

※ : Standard

## 40D-9F



Mast Type	Maximum Fork Height		Overall Height (Lowered)				Free lift height				Tilt Angle		Load capacity w/o side shift				Load capacity w/side shift				TRUCK WEIGHT (UNLOADED)				
			Single Tire		Double Tire		With Load Backrest		Without Load Backrest		Fwd	Bwd	Single Tire		Double Tire		Single Tire		Double Tire		Single Tire		Double Tire		
			in	mm	in	mm	in	mm	in	mm			24 in LC	600mm LC	24 in LC	600mm LC	24 in LC	600mm LC	24 in LC	600mm LC	24 in LC	600mm LC	24 in LC	600mm LC	24 in LC
	in		mm		in		mm		deg		deg		lb		kg		lb		kg		lb		kg		
2-STAGE LIMITED FREE LIFT	V270	107.1	2,720	82.1	2,085	81.5	2,070	4.7	120	4.7	120	8	10	9,000	4,000	9,000	4,000	9,000	4,000	9,000	4,000	13,842	6,292	14,098	6,408
	※V300	118.9	3,020	88.0	2,235	87.4	2,220	4.7	120	4.7	120	8	10	9,000	4,000	9,000	4,000	9,000	4,000	9,000	4,000	13,908	6,322	14,164	6,438
	V330	130.7	3,320	93.9	2,385	93.3	2,370	4.7	120	4.7	120	8	10	9,000	4,000	9,000	4,000	9,000	4,000	9,000	4,000	13,992	6,360	14,247	6,476
	V350	138.6	3,520	99.8	2,535	99.2	2,520	4.7	120	4.7	120	8	10	9,000	4,000	9,000	4,000	9,000	4,000	9,000	4,000	14,043	6,383	14,298	6,499
	V370	146.5	3,720	103.7	2,635	103.1	2,620	4.7	120	4.7	120	8	10	9,000	4,000	9,000	4,000	8,888	3,950	8,888	3,950	14,087	6,403	14,342	6,519
	V400	158.3	4,020	112.0	2,845	111.4	2,830	4.7	120	4.7	120	8	10	9,000	4,000	9,000	4,000	8,775	3,900	8,775	3,900	14,181	6,446	14,436	6,562
	V430	170.1	4,320	117.9	2,995	117.3	2,980	4.7	120	4.7	120	8	10	9,000	4,000	9,000	4,000	8,663	3,850	8,663	3,850	14,245	6,475	14,500	6,591
	V450	178.0	4,520	121.9	3,095	121.3	3,080	4.7	120	4.7	120	8	6	9,000	4,000	9,000	4,000	8,550	3,800	8,550	3,800	14,428	6,558	14,683	6,674
V500	197.6	5,020	131.7	3,345	131.1	3,330	4.7	120	4.7	120	8	6	8,775	3,900	9,000	4,000	8,325	3,700	8,325	3,700	14,540	6,609	14,795	6,725	
2-STAGE FULL	VF280	110.4	2,805	84.1	2,135	83.5	2,120	36.1	91.6	48.9	1,243	8	8	9,000	4,000	9,000	4,000	9,000	4,000	9,000	4,000	13,970	6,350	14,181	6,446
FREE LIFT	VF300	118.3	3,005	88.0	2,235	87.4	2,220	40.0	1,016	52.9	1,343	8	8	9,000	4,000	9,000	4,000	9,000	4,000	9,000	4,000	14,027	6,376	14,238	6,472
	VF315	124.2	3,155	91.5	2,325	90.9	2,310	43.5	1,106	56.4	1,433	8	8	9,000	4,000	9,000	4,000	9,000	4,000	9,000	4,000	14,069	6,395	14,280	6,491
3-STAGE FULL FREE LIFT	TF/TS370	146.9	3,730	80.1	2,035	79.5	2,020	31.8	80.7	44.6	1,134	8	8	9,000	4,000	9,000	4,000	8,775	3,900	8,888	3,950	14,379	6,536	14,509	6,595
	TF/TS400	158.7	4,030	84.1	2,135	83.5	2,120	35.7	90.7	48.6	1,234	8	8	9,000	4,000	9,000	4,000	8,663	3,850	8,663	3,850	14,445	6,566	14,575	6,625
	TF/TS430	170.5	4,330	88.0	2,235	87.4	2,220	39.6	1,007	52.5	1,334	8	8	9,000	4,000	9,000	4,000	8,550	3,800	8,550	3,800	14,513	6,597	14,643	6,656
	TF/TS450	177.6	4,510	90.4	2,295	89.8	2,280	42.0	1,067	54.9	1,394	8	8	9,000	4,000	9,000	4,000	8,550	3,800	8,550	3,800	14,555	6,616	14,685	6,675
	TF/TS470	185.8	4,720	93.9	2,385	93.3	2,370	45.6	1,157	58.4	1,484	8	8	9,000	4,000	9,000	4,000	8,325	3,700	8,438	3,750	14,637	6,653	14,764	6,711
	TF/TS500	197.6	5,020	97.8	2,485	97.2	2,470	49.5	1,257	62.4	1,584	8	6	8,775	3,900	8,775	3,900	8,100	3,600	8,213	3,650	14,687	6,676	14,815	6,734
	TF/TS550	217.3	5,520	104.9																					

## 45D-9F



Mast Type	Maximum Fork Height		Overall Height (Lowered)				Free lift height				Tilt Angle		Load capacity w/o side shift				Load capacity w/side shift				TRUCK WEIGHT (UNLOADED)										
			Single Tire		Double Tire		With Load Backrest		Without Load Backrest		Fwd	Bwd	Single Tire		Double Tire		Single Tire		Double Tire		Single Tire		Double Tire								
	in	mm	in	mm	in	mm	in	mm	in	mm	deg	deg	24 in LC	600mm LC	24 in LC	600mm LC	24 in LC	600mm LC	24 in LC	600mm LC	24 in LC	600mm LC	lb	kg	lb	kg	lb	kg	lb	kg	
	2-STAGE LIMITED	V270	107.1	2,720	82.1	2,085	81.5	2,070	4.7	120	4.7	120	8	10	10,000	4,500	10,000	4,500	10,000	4,500	10,000	4,500	14,744	6,702	15,101	6,864					
※V300		118.9	3,020	88.0	2,235	87.4	2,220	4.7	120	4.7	120	8	10	10,000	4,500	10,000	4,500	10,000	4,500	10,000	4,500	14,810	6,732	15,167	6,894						
V330		130.7	3,320	93.9	2,385	93.3	2,370	4.7	120	4.7	120	8	10	10,000	4,500	10,000	4,500	10,000	4,500	10,000	4,500	14,894	6,770	15,250	6,932						
V350		138.6	3,520	99.8	2,535	99.2	2,520	4.7	120	4.7	120	8	10	10,000	4,500	10,000	4,500	10,000	4,500	10,000	4,500	14,945	6,793	15,301	6,955						
V370		146.5	3,720	103.7	2,635	103.1	2,620	4.7	120	4.7	120	8	10	10,000	4,500	10,000	4,500	9,680	4,400	9,680	4,400	14,989	6,813	15,345	6,975						
2-STAGE LIMITED FREE LIFT	V400	158.3	4,020	112.0	2,845	111.4	2,830	4.7	120	4.7	120	8	10	10,000	4,500	10,000	4,500	9,570	4,350	9,570	4,350	15,081	6,855	15,437	7,017						
	V430	170.1	4,320	115.9	2,945	117.3	2,980	4.7	120	4.7	120	8	10	10,000	4,500	10,000	4,500	9,460	4,300	9,460	4,300	15,147	6,885	15,503	7,047						
	V450	178.0	4,520	121.9	3,095	121.3	3,080	4.7	120	4.7	120	8	6	10,000	4,500	10,000	4,500	9,240	4,200	9,240	4,200	15,330	6,968	15,686	7,130						
	V500	197.6	5,020	131.7	3,345	131.1	3,330	4.7	120	4.7	120	8	6	9,680	4,400	9,680	4,400	8,910	4,050	8,910	4,050	15,442	7,019	15,798	7,181						
	VF280	110.4	2,805	84.1	2,135	83.5	2,120	33.6	85.3	56.8	1,442	8	8	10,000	4,500	10,000	4,500	10,000	4,500	10,000	4,500	14,826	6,739	15,125	6,875						
2-STAGE FULL	VF300	118.3	3,005	88.0	2,235	87.4	2,220	37.5	95.3	60.7	1,542	8	8	10,000	4,500	10,000	4,500	10,000	4,500	10,000	4,500	14,883	6,765	15,182	6,901						
	VF315	124.2	3,155	91.5	2,325	90.9	2,310	41.1	1,043	63.1	1,602	8	8	10,000	4,500	10,000	4,500	10,000	4,500	10,000	4,500	14,925	6,784	15,224	6,920						
3-STAGE LIMITED	TF/TS370	146.9	3,730	80.1	2,035	79.5	2,020	31.3	79.6	43.9	1,114	8	8	10,000	4,500	10,000	4,500	9,570	4,350	9,570	4,350	15,248	6,931	15,547	7,067						
	TF/TS400	158.7	4,030	84.1	2,135	83.5	2,120	35.3	89.6	47.8	1,214	8	8	10,000	4,500	10,000	4,500	9,460	4,300	9,460	4,300	15,314	6,961	15,613	7,097						
	TF/TS430	170.5	4,330	88.0	2,235	87.4	2,220	39.2	99.6	51.7	1,314	8	8	10,000	4,500	10,000	4,500	9,240	4,200	9,240	4,200	15,382	6,992	15,682	7,128						
	TF/TS450	177.6	4,510	90.4	2,295	89.8	2,280	41.6	1,056	54.1	1,374	8	8	10,000	4,500	10,000	4,500	9,130	4,150	9,130	4,150	15,424	7,011	15,723	7,147						
	TF/TS470	185.8	4,720	93.9	2,385	93.3	2,370	45.1	1,145	58.4	1,484	8	8	9,680	4,400	9,680	4,400	9,020	4,100	9,020	4,100	15,503	7,047	15,803	7,183						
3-STAGE LIMITED FREE LIFT	TF/TS500	197.6	5,020	97.8	2,485	97.2	2,470	49.1	1,246	61.6	1,564	8	6	9,460	4,300	9,460	4,300	8,800	4,000	8,800	4,000	15,554	7,070	15,853	7,206						
	TF/TS550	217.3	5,520	104.9	2,665	104.3	2,650	56.1	1,426	68.7	1,744	8	6	9,240	4,200	9,240	4,200	8,470	3,850	8,470	3,850	15,690	7,132	15,990	7,268						
	TF/TS600	237.4	6,030	112.0	2,845	111.4	2,830	63.2	1,606	75.7	1,924	8	6	8,800	4,000	8,800	4,000	7,150	3,250	8,250	3,750	15,833	7,197	16,133	7,333						
	TF/TS650	257.5	6,540	119.1	3,025	118.5	3,010	70.3	1,786	82.8	2,104	8	6	8,580	3,900	8,580	3,900	6,930	3,150	8,030	3,650	16,025	7,284	16,324	7,420						

※ TF-Mast : Wide Visible 3-Stage Full Free Lift Mast with 1 Free Lift Cylinder

※ TS-Mast : Wide Visible 3-Stage Full Free Lift Mast with 2 Free Lift Cylinders

※ : Standard

## 50DA-9F



Mast Type	Maximum Fork Height		Overall Height (Lowered)				Free lift height				Tilt Angle		Load capacity w/o side shift				Load capacity w/side shift				TRUCK WEIGHT (UNLOADED)										
			Single Tire		Double Tire		With Load Backrest		Without Load Backrest		Fwd	Bwd	Single Tire		Double Tire		Single Tire		Double Tire		Single Tire		Double Tire								
	in	mm	in	mm	in	mm	in	mm	in	mm	deg	deg	24 in LC	600mm LC	24 in LC	600mm LC	24 in LC	600mm LC	24 in LC	600mm LC	24 in LC	600mm LC	lb	kg	lb	kg	lb	kg	lb	kg	
	2-STAGE LIMITED	V260	103.5	2,630	82.1	2,085	81.5	2,070	4.7	120	4.7	120	8	10	11,000	5,000	11,000	5,000	11,000	5,000	11,000	5,000	15,734	7,152	16,001	7,273					
※V290		115.4	2,930	88.0	2,235	87.4	2,220	4.7	120	4.7	120	8	10	11,000	5,000	11,000	5,000	11,000	5,000	11,000	5,000	15,789	7,177	16,056	7,298						
V320		127.2	3,230	93.9	2,385	93.3	2,370	4.7	120	4.7	120	8	10	11,000	5,000	11,000	5,000	11,000	5,000	11,000	5,000	15,844	7,202	16,111	7,323						
V340		135.0	3,430	99.8	2,535	99.2	2,520	4.7	120	4.7	120	8	10	11,000	5,000	11,000	5,000	10,890	4,950	10,890	4,950	15,899	7,227	16,166	7,348						
V360		142.9	3,630	103.7	2,635	103.1	2,620	4.7	120	4.7	120	8	10	11,000	5,000	11,000	5,000	10,780	4,900	10,780	4,900	15,935	7,243	16,201	7,364						
2-STAGE LIMITED FREE LIFT	V390	154.7	3,930	112.0	2,845	111.4	2,830	4.7	120	4.7	120	8	10	11,000	5,000	11,000	5,000	10,560	4,800	10,560	4,800	16,014	7,279	16,280	7,400						
	V440	174.4	4,430	121.9	3,095	121.3	3,080	4.7	120	4.7	120	8	6	10,780	4,900	11,000	5,000	10,230	4,650	10,230	4,650	16,240	7,382	16,507	7,503						
	V490	194.1	4,930	131.7	3,345	131.1	3,330	4.7	120	4.7	120	8	6	10,560	4,800	10,780	4,900	9,900	4,500	9,900	4,500	16,333	7,424	16,599	7,545						
	VF270	106.4	2,702	84.1	2,135	83.5	2,120	35.6	90.5	48.1	1,223	8	8	11,000	5,000	11,000	5,000	10,340	4,700	10,450	4,750	15,657	7,117	15,924	7,238						
	VF290	114.3	2,902	88.0	2,235	87.4	2,220	39.6	1,005	52.1	1,323	8	8	11,000	5,000	11,000	5,000	10,230	4,650	10,340	4,700	15,715	7,143	15,981	7,264						
2-STAGE LIMITED FREE LIFT	VF305	120.2	3,052	91.5	2,325	90.9	2,310	43.1	1,095	55.6	1,413	8	8	11,000	5,000	11,000	5,000	10,010	4,550	10,120	4,600	15,756	7,162	16,023	7,283						
	TF/TS360	144.6	3,672	80.1	2,035	79.5	2,020	31.8	80.7	42.3	1,074	8	8	11,000	5,000	11,000	5,000	10,340	4,700	10,560	4,800	16,166	7,348	16,432	7,469						
3-STAGE LIMITED	TF/TS390	156.4	3,972	84.1	2,135	83.5	2,120	35.7	90.7	46.2	1,174	8	8	11,000	5,000	11,000	5,000	10,230	4,650	10,340	4,700	16,223	7,374	16,489	7,495						
	TF/TS420	168.2	4,272	88.0	2,235	87.4	2,220	39.6	1,007	50.2	1,274	8	8	10,780	4,900	11,000	5,000	10,010	4,550	10,120	4,600	16,278	7,399	16,544	7,520						
	TF/TS440	175.3	4,452	90.4	2,295	89.8	2,280	42.0	1,067	52.5	1,334	8	8	10,560	4,800	11,000	5,000	9,900													

# New 9 Series

**35/40/45D-9F**  
**50DA-9F**

## Load Capacity

35D-9F

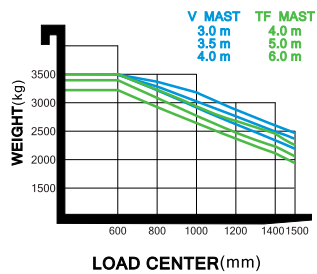

40D-9F

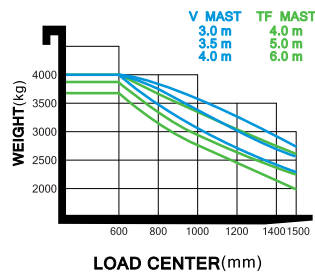

45D-9F

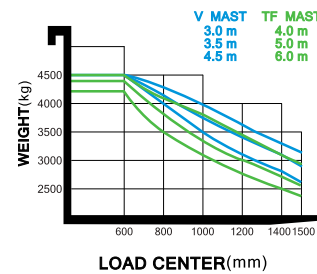

50DA-9F

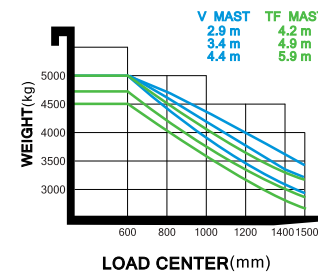

## Optional Items

- Fork(mm)
    - 35D-9F : 1070 (Std), 1220, 1370, 1520, 1670, 1820, 1970, 2120, 2400
    - 40/45D-9F : 1070, 1220 (Std), 1370, 1520, 1670, 1820, 1970, 2200, 2400
    - 50DA-9F : 1200 (Std), 1350, 1500, 1800, 2000, 2400
  - Tire : pneumatic pressure (standard feature)  
(Solid, Non-marking / Front wheel single or Double tire)
  - M.C.V : 3-spool, 4-spool (OPT)
  - Rear view camera
- Cabin
  - Seat : Head Rest , Hot wire / Under cover
  - Air-conditioner / Heater-integrated heater
  - Pneumatic temperature / Pressure monitoring system
  - Master switch
  - Under cover
  - Rear Horn
  - LED Work Lamp

## Attachments

Side shift

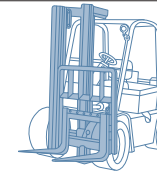

Hinged fork

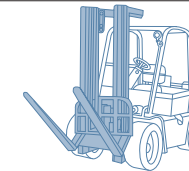

Hinged bucket



Rotating fork

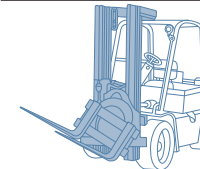

Push pull

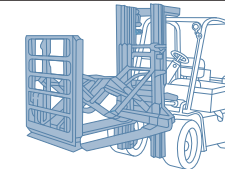

Rotating roll clamp

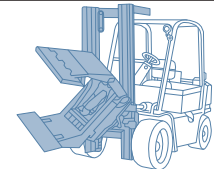

Load stabilizer

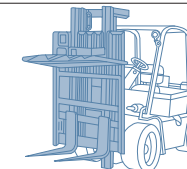

Carton clamp

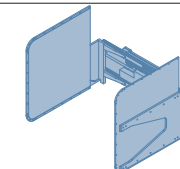

Pallet inverter

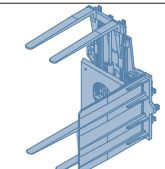

Drum clamp

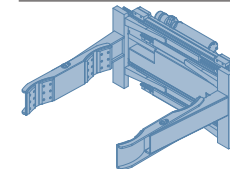

Veil clamp

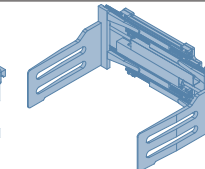

Load extender

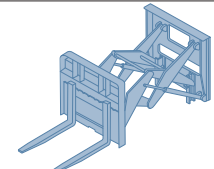

Fork positioner

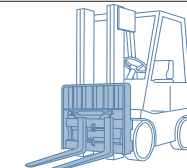

\* All specifications and photos in this catalog are subject to change for quality improvement.

## Specification

Distinguishing mark						
1.1	Manufacturer	Hyundai				
1.2	Manufacturer's type designation	35D-9F	40D-9F	45D-9F	50D-9F	
1.3	Drive	Diesel	Diesel	Diesel	Diesel	
1.4	Type of operation	Seated	Seated	Seated	Seated	
1.5	Load capacity	lb/kg	7,700/3,500	8,800/4,000	9,900/4,500	11,000/5,000
1.6	Load center distance	c in/mm	24/600	24/600	24/600	24/600
1.8	Load distance, center of drive axle to fork	x in/mm	22/56	22/561	22/561	23/576
1.9	Wheelbase	y in/mm	79/2,000	79/2,000	79/2,000	79/2,000
Weights						
21	Service weight	lb/kg	12,992/5,893	14,193/6,438	15,199/6,894	16,089/7,298
22	Axle loading, loaded front - rear	lb/kg	18,082-2,628/8,202-1,192	20,082-2,930/9,109-1,329	21,757-3,362/9,869-1,525	23,558-3,554/10,686-1,612
23	Axle loading, unloaded front - rear	lb/kg	5,891-7,324/2,672-3,222	6,149-8,045/2,789-3,649	6,083-9,116/2,759-4,135	6,140-9950/2,786-4,512
Tires, chassis						
3.1	Tires : pneumatic, solid rubber, non marking		P	P	P	P
3.2	Front tire size (0 x width)		8.25-15-14PR	7.50-16-12PR	7.50-16-12PR	7.50-16-12PR
3.3	Rear tire size (0 x width)		7.00-12-12PR	7.00-12-12PR	7.00-12-12PR	7.00-12-12PR
3.5	Wheels, number front rear (x = driven wheels)		2 x 2	4 x 2	4 x 2	4 x 2
3.6	Track width (front)	in/mm	44.5/1,132	50.4/1,282	50.4/1,282	50.4/1,282
3.7	Track width (rear)	in/mm	44.8/1,140	44.8/1,140	44.8/1,140	44.8/1,140
Dimensions						
4.1	Tilt of mast/fork carriage forward/backward	degrees	8 / 10	8 / 10	8 / 10	8 / 10
4.2	Height, mast lowered	h1 in/mm	88/2,235	87/2,220	87/2,220	87/2,220
4.3	Free lift height	h2 in/mm	4.7/120	4.7/120	4.7/120	4.7/120
4.4	Lift Height	h3 in/mm	119/3,020	119/3,020	119/3,020	115/2,930
4.5	Extended mast height	h4 in/mm	167/4,234	167/4,234	167/4,234	163/4,147
4.7	Overhead guard (cab) height	h5 in	87.4 (93)	87 (92.5)	87 (92.5)	87 (92.5)
		h5 mm	2,220 (2,360)	2,210 (2,350)	2,210 (2,350)	2,210 (2,350)
4.8	Seat height / stand height rel. to sip	h7 in/mm	42/1070	42/1070	42/1070	42/1070
4.12	Coupling height	h10 in/mm	14/364	14/364	14/364	14/364
4.19	Overall length	l1 in/mm	165/4,180	167/4,25	175/4,455	177/4,500
4.20	Length to face of forks	l2 in/mm	122/3,110	125/3,165	127/3,235	130/3,300
4.21	Overall Width	b1 in/mm	54/1,370	69/1,740	69/1,740	69/1,740
4.22	Fork dimension (length x width x thickness)	in/mm	42.1 x 4.8 x 1.9/1,070 x 122 x 50	42.1 x 5.9 x 1.9/1,070 x 150 x 50	48.0 x 5.9 x 1.9/1,220 x 150 x 50	47.2 x 5.9 x 2.3/1,200 x 150 x 60
4.23	Fork carriage ISO 2328, class / type A, B		III / A	III / A	IV / A	IV / A
4.24	Fork - carriage width	b3 in/mm	51/1,300	63/1,600	63/1,600	63/1,600
4.31	Minimum ground clearance (mast)	m1 in/mm	6.6/170	6.1/155	6.1/155	6.1/155
4.32	Minimum ground clearance (center of wheelbase)	m2 in/mm	8.4/215	8.0/205	8.0/205	7.8/200
4.33	Aisle Width For Pallets 1000 x 1200 Crossways (LxW)	Ast in/mm	182/4,629	184/4,676	186/4,726	188/4,771
4.34	Aisle Width Of Pallets 800 x 1200 Crossways (W L)	Ast in/mm	190/4,829	192/4,876	194/4,926	196/4,971
4.35	Turning radius	Wa in/mm	113/2,868	115/2,915	117/2,965	119/3,010
4.36	Smallest pivot point distance	Wa in/mm	40/1,009	40/1,009	40/1,009	40/1,009

Performance data						
5.1	Travel speed, unloaded	mph - kmh	12.2/26.6	11.9/25.7	11.9/25.6	11.8/25.6
5.2	Lift speed, loaded / unloaded	in/s - mm/s	19.6/21.2-500/540	18.8/21.2-480/540	18.8/21.2-480/540	16.1/18.1-410/460
5.3	Lowering speed, loaded / unloaded	in/s / mm/s	19.6/19.6-500/500	19.6/19.6-500/500	19.6/19.6-500/500	19.6/19.6-500/500
5.5	Drawbar pull, loaded	lb/kg	8,307/3,768	8,371/3,797	8,380/3,801	8,393/3,807
5.7	Gradient performance, loaded	%	38.6	34.6	31.4	28.9
5.9	Acceleration time, loaded/ unloaded(10m)	sec	-	-	-	-
5.10	Service brake		Hydraulic type	Hydraulic type	Hydraulic type	Hydraulic type
Combustion-engine						
6.1	Engine manufacturer / type		KUBOTA V3800 - TIER 4			
6.2	Engine power acc. to ISO 1585	HP/kW@rpm	75.3 / 2,200			
6.3	Maximum Torque	lb-ft/kgf-m@rpm	31.6 / 1,500			
6.4	No. of cylinder / cubic capacity	EA/cc	4 / 3,769			
6.5	Capacity of Fuel tank	GAL/l/h	132			
Addition data						
8.1	Type of drive control		Power shift 2/2	Power shift 2/2	Power shift 2/2	Power shift 2/2
8.2	Operating pressure, system / attachments	PSI	2987/2132	2987/2132	2987/2132	2987/2132
		kgf/cm2	206 / 147	206 / 147	206 / 147	206 / 147
8.3	Attachment oil capacity	gal/l/min	20/76	20/76	20/76	20/76
8.5	Trailer coupling, type DIN		PIN			

## Dimension

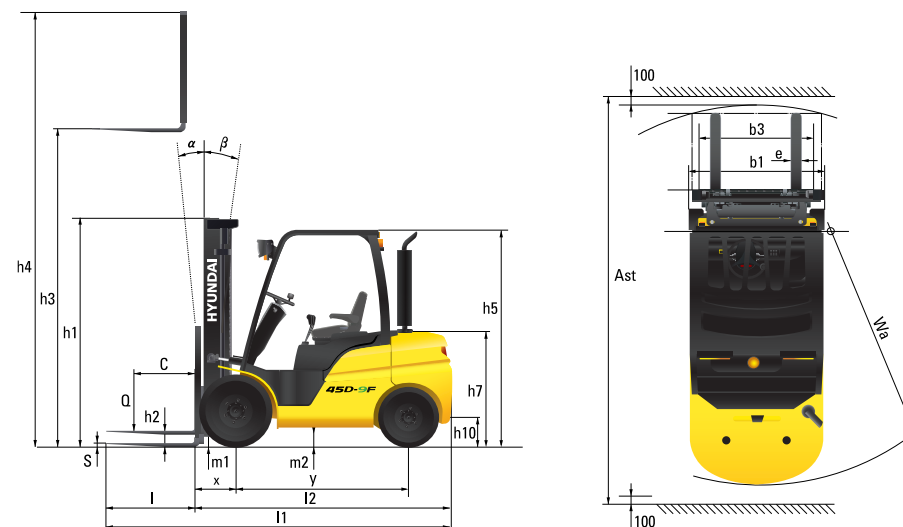

\* All specifications in this catalog are subject to change according to the optional items.



**MONTREAL (Head office)**

100A, Hymus Blvd.  
Pointe-Claire (Québec) H9R 1E4  
Phone: 514 694-4223  
Toll free: 1 866 421-4223  
info@elevex.ca

**SAGUENAY**

2305, Alexis-Le-Trotteur Street  
Jonquière (Québec) G7X 9H8  
Phone : 418 543-0000  
Toll free: 1 866 421-4223